

B 5 E

EN

OPERATING MANUAL
HUMIDIFIER



 **TROTEC**

Table of contents

Notes regarding the operating manual..... 2

Safety 2

Information about the device..... 4

Transport and storage..... 5

Assembly and installation..... 6

Operation 8

Available accessories..... 11

Errors and faults..... 12

Maintenance 13

Technical annex..... 17

Notes regarding the operating manual

Symbols



Warning of electrical voltage

This symbol indicates dangers to the life and health of persons due to electrical voltage.



Warning

This signal word indicates a hazard with an average risk level which, if not avoided, can result in serious injury or death.



Caution

This signal word indicates a hazard with a low risk level which, if not avoided, can result in minor or moderate injury.

Note

This signal word indicates important information (e.g. material damage), but does not indicate hazards.



Info

Information marked with this symbol helps you to carry out your tasks quickly and safely.



Follow the manual

Information marked with this symbol indicates that the operating manual must be observed.

You can download the current version of the operating manual and the EU declaration of conformity via the following link:

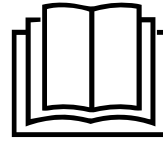

B 5 E



<https://hub.trotec.com/?id=41495>

Safety

Read this manual carefully before starting or using the device. Always store the manual in the immediate vicinity of the device or its site of use.



Warning

Read all safety warnings and all instructions.

Failure to follow the warnings and instructions may result in electric shock, fire and/or serious injury.

Save all warnings and instructions for future reference.

This appliance can be used by children aged from 8 years and above and persons with reduced physical, sensory or mental capabilities or lack of experience and knowledge if they have been given supervision or instruction concerning use of the appliance in a safe way and understand the hazards involved.

Children shall not play with the appliance. Cleaning and user maintenance shall not be made by children without supervision.

- Do not use the device in potentially explosive rooms or areas and do not install it there.
- Do not use the device in aggressive atmosphere.
- Only put up the device in an upright, stable position on firm ground.
- Do not expose the device to directly squirting water.
- Fill the device with fresh drinking water only.
- Never insert any objects or limbs into the device.
- Do not cover or transport the device during operation.
- Do not sit on the device.
- This appliance is not a toy! Keep away from children and animals. Do not leave the device unattended during operation.
- Ensure that all electric cables outside of the device are protected from damage (e.g. caused by animals). Never use the device if electric cables or the power connection are damaged!

- The electrical connection must correspond to the specifications in chapter Technical data.
- Insert the mains plug into a properly secured mains socket.
- Observe the device's power input, cable length and intended use when selecting extensions to the power cable. Completely unroll extension cables. Avoid electrical overload.
- Before carrying out maintenance, care or repair work on the device, remove the mains plug from the mains socket. Hold onto the mains plug while doing so.
- Switch the device off and disconnect the power cable from the mains socket when the device is not in use.
- Do not under any circumstances use the device if you detect damages on the mains plug or power cable. If the supply cord is damaged, it must be replaced by the manufacturer, its service agent or similarly qualified persons in order to avoid a hazard.
Defective power cables pose a serious health risk!
- Make sure that the air inlet and outlet are not obstructed.
- Make sure that the suction side is kept free of dirt and loose objects.
- Do not remove any safety signs, stickers or labels from the device. Keep all safety signs, stickers and labels in legible condition.
- Do not use the device when the water tank is empty.
- Before filling the water tank, switch the device off and disconnect the power cable from the mains socket. Hold onto the mains plug while doing so.
- Only transport the device in an upright position with an emptied water tank.
- Empty the water tank before transport and storage. Do not drink the water. Health hazard!
- Note that high humidity levels may enhance the growth of biological organisms in the environment.
- Make sure that objects in the surroundings of the device do not become wet or damp. If moisture is present, the output must be reduced. If the output cannot be reduced, the device must only be operated in intervals. Absorbent materials such as carpeting, curtains, sheers or tablecloths must not become damp.
- Make sure that the water in the water tank is replaced every 3 days. Otherwise there is a risk of microorganisms growing in the water tank which presents a health hazard if they get into the air or water.

Intended use

Only use the device B 5 E as a mobile humidifier for the humidification and filtration of room air, while adhering to and following the technical data.

Intended use comprises humidifying the room air in:

- living spaces
- warehouses and archives
- libraries
- call centres and computer rooms

Improper use

The device is not intended for industrial use.

- Do not place the device on wet or flooded ground.
- Do not place any objects, e.g. clothing, on the device.
- Do not use the device outdoors.
- Any unauthorised modifications, alterations or structural changes to the device are forbidden.
- Any operation other than as described in this manual is prohibited. Non-observance renders all claims for liability and guarantee null and void.

Personnel qualifications

People who use this device must:

- be aware of the dangers that occur when working with electric devices in damp areas.
- have read and understood the operating manual, especially the Safety chapter.

Safety signs and labels on the device

Note

Do not remove any safety signs, stickers or labels from the device. Keep all safety signs, stickers and labels in legible condition.

The following safety signs and labels are attached to the device:

Symbols	Meaning
	This symbol located on the device indicates that the filter has to be checked and, if necessary, to be cleaned prior to each operation. Replace the filter if it is defective. Do not insert a wet filter into the device. Wait until the filter has dried.

Symbols	Meaning
	This symbol located on the device indicates that the water tank should be cleaned every 3 days. Change the water in the water tank every 3 days. Disconnect the device from the mains before cleaning the water tank.

Residual risks



Warning of electrical voltage

Work on the electrical components must only be carried out by an authorised specialist company!



Warning of electrical voltage

Before any work on the device, remove the mains plug from the mains socket!
Hold onto the mains plug while pulling the power cable out of the mains socket.



Warning

Dangers can occur at the device when it is used by untrained people in an unprofessional or improper way! Observe the personnel qualifications!



Warning

The device is not a toy and does not belong in the hands of children.



Warning

Risk of suffocation!
Do not leave the packaging lying around. Children may use it as a dangerous toy.



Caution

If the device is knocked over, water will leak from the lower part.
Disconnect the device from the mains to prevent damage to the device caused by dry running.

Note

Do not operate the device without an air filter inserted into the air inlet!
Without the air filter, the inside of the device will be heavily contaminated. This could reduce the performance and result in damage to the device.

Behaviour in the event of an emergency

1. Switch off the device.
2. In an emergency, disconnect the device from the mains feed-in: Hold onto the mains plug while pulling the power cable out of the mains socket.
3. Do not reconnect a defective device to the mains.

Information about the device

Description of the device

The device B 5 E functions as a humidifier and air cleaner. The ultrasound technology ensures a pleasant room climate and air quality improvement.
The on-demand ionization function promotes the removal of harmful substances and odours from the room air.
The device comes with an automatic mode, a baby mode and a night mode. Moreover, a timer can be programmed for automatic switch-off after 1 to 12 hours.
The capacity of the water tank allows for a runtime of up to 13 hours.
When the device is in operation, the water tank can be additionally illuminated by blue LEDs located in the lower part of the device.

Device depiction

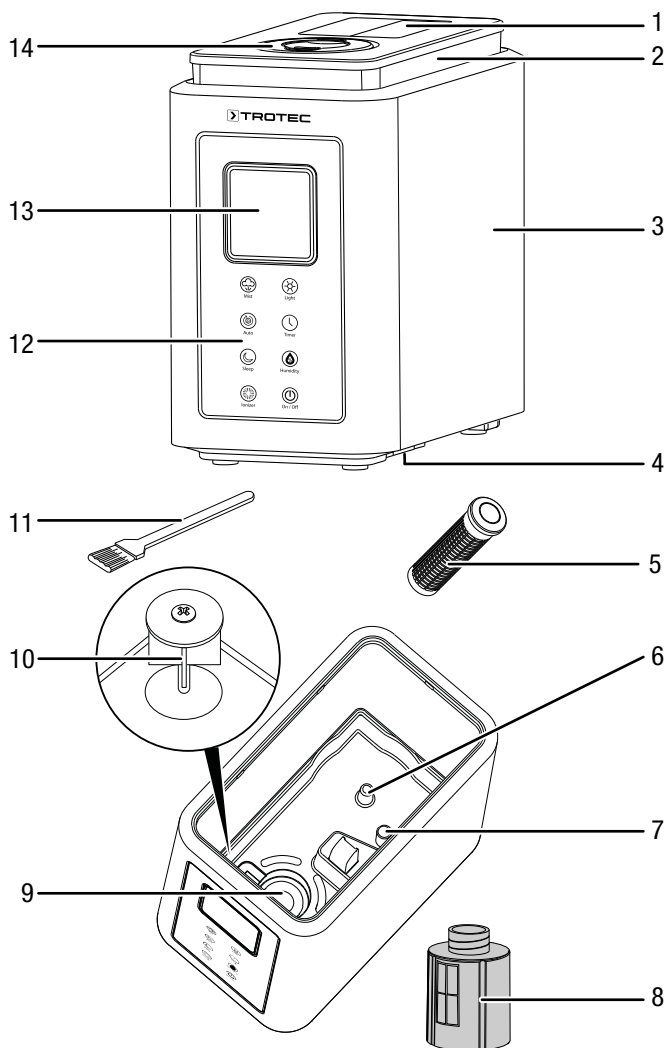

No.	Designation
1	Water tank transport handle
2	Water tank
3	Lower part
4	Carbon filter
5	SecoSan® Stick 10 (optional accessory)
6	Water tank connection
7	Overflow
8	Filter cartridge with water softener
9	Nebulizer membrane
10	Float
11	Brush
12	Control panel
13	Display
14	Mist nozzle

Transport and storage

Note

If you store or transport the device improperly, the device may be damaged.
Note the information regarding transport and storage of the device.

Transport

Before transporting the device, observe the following:

- Switch off the device.
- Hold onto the mains plug while pulling the power cable out of the mains socket.
- Empty the water tank.
- Do not use the power cable to drag the device.
- Check whether the upper part is correctly positioned on the lower part.
- Lift the device at the lower part.

After transporting the device, observe the following:

- Set up the device in an upright position after transport.

Storage

Before storing the device, observe the following:

- Hold onto the mains plug while pulling the power cable out of the mains socket.
- Empty the water tank.
- Empty the lower part.
- Use a cloth to wipe all parts of the device dry.
- Clean the device according to the Maintenance chapter.

When the device is not being used, observe the following storage conditions:

- dry and protected from frost and heat
- in an upright position where it is protected from dust and direct sunlight
- with a cover to protect it from invasive dust, if necessary
- Place no further devices or objects on top of the device to prevent it from being damaged.

Assembly and installation

Scope of delivery

- 1 x Device
- 1 x Water softener
- 1 x Brush
- 1 x Manual

Unpacking the device

1. Open the cardboard box and take the device out.
2. Completely remove the packaging.
3. Fully unwind the power cable. Make sure that the power cable is not damaged and that you do not damage it during unwinding.

Start-up

- Before restarting the device, check the condition of the power cable. If there are doubts as to the sound condition, contact the customer service.
- Only put up the device in an upright, stable position on firm ground.
- Do not create tripping hazards when laying the power cable or other electric cables, especially when positioning the device in the middle of the room. Use cable bridges.
- Make sure that extension cables are unrolled completely.
- Make sure that there are no moisture-sensitive objects located in the immediate vicinity of the mist nozzle, since water may condense near the mist nozzle.

Filling the water tank

The water tank should be filled before first use or when the empty water tank indication (21) lights up.

Note

Fill the device with fresh drinking water only. The water temperature must not exceed 40 °C. Scented oil or other additives can damage the plastics and the nebulizer membrane.



Info

If possible, change the water every 3 days to prevent bacterial growth.

1. Remove the water tank (2) from the device by lifting the water tank at the transport handle (1).
Note that there may still be residual water left in the lower part (3) if the device was used beforehand.

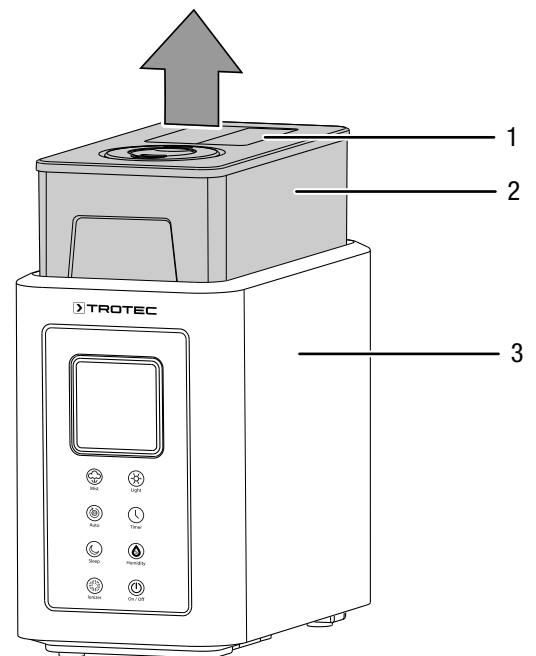

2. Remove the mist nozzle (14) from the water tank to prevent the mist nozzle from falling out when the water tank is turned over.

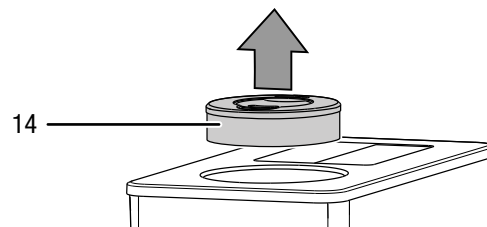

3. Turn the water tank over.

4. Unscrew the lid (15) from the water tank (2).

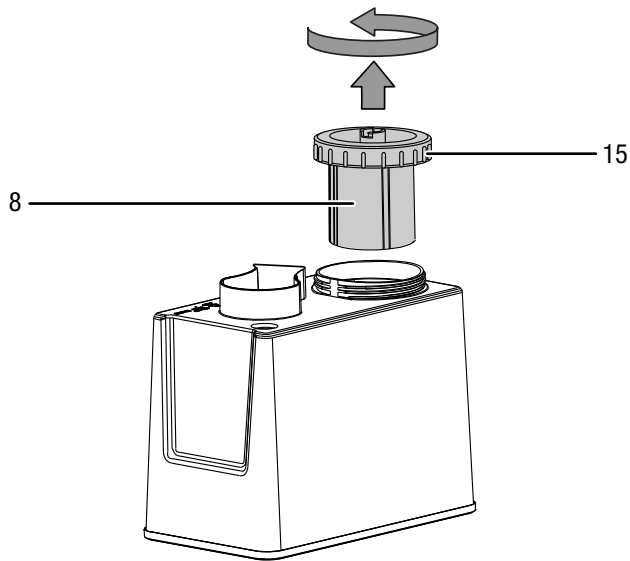

5. Fill fresh drinking water (approx. 4 l, maximally 40 °C) into the water tank.
 6. Insert the SecoSan® Stick (optional accessory) (7) into the water tank (1).
 7. Screw the lid (15) firmly back onto the water tank (2).

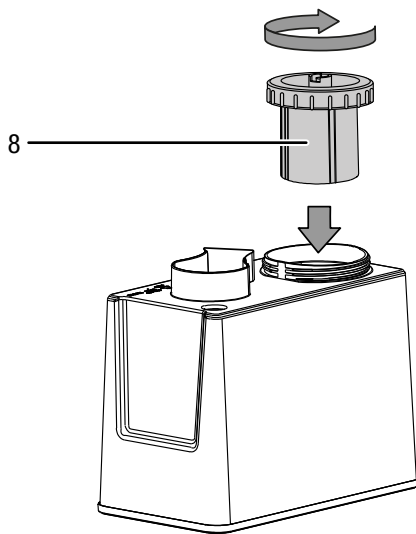

8. Refit the mist nozzle (14) onto the water tank (2).

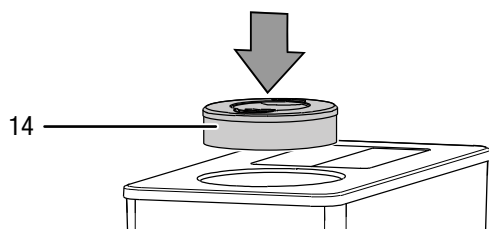

9. Refit the water tank (2) into the device.
 ⇨ In doing so, make sure that the arrow points to the front.
 ⇨ Please note that after inserting the water tank, the water starts to run into the lower part of the device immediately.

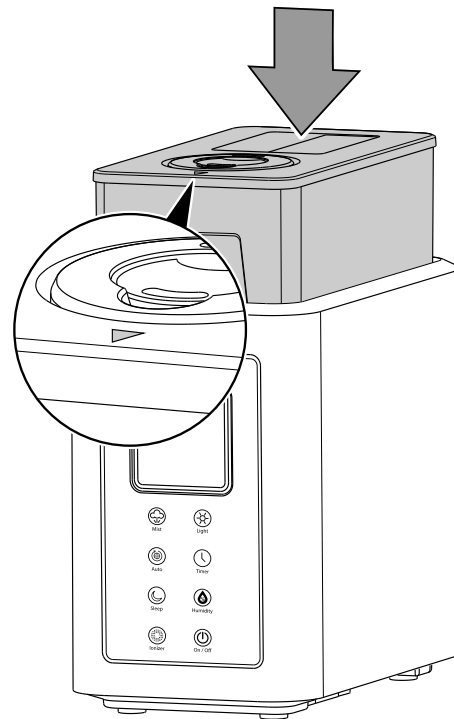

10. Set the device up in an upright and stable position.
 ⇨ If the device is not positioned upright, the water inside the device will be discharged from the device via the overflow (7).

Inserting the air filter

Note

Do not operate the device without an air filter inserted into the air inlet!

Without the air filter, the inside of the device will be heavily contaminated. This could reduce the performance and result in damage to the device.

- Make sure that the air filter is installed before switching the device on.

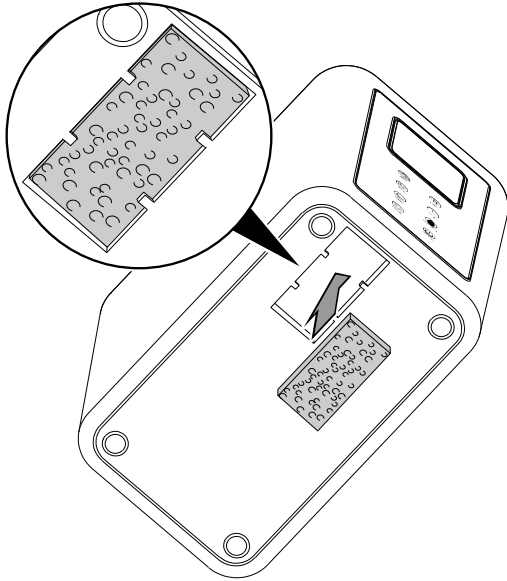

Connecting the power cable

- Insert the mains plug into a properly secured mains socket.
- The operation indication (19) lights up and an acoustic confirmation signal is emitted.

Operation

- Avoid open doors and windows.

Display

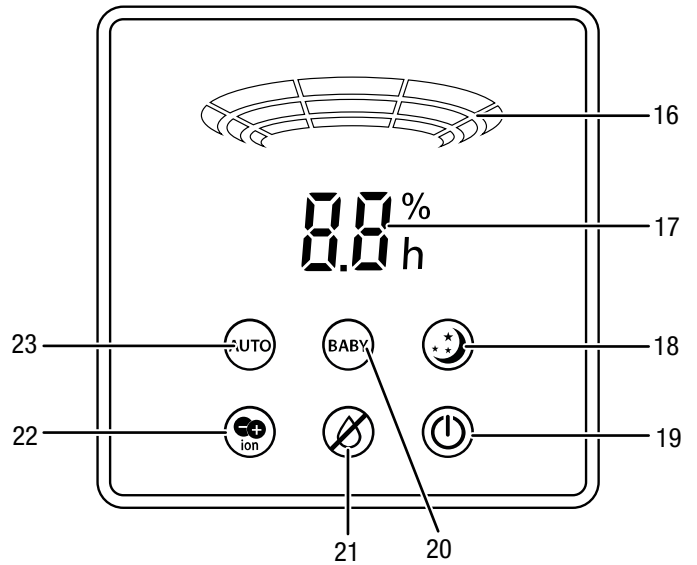

No.	Designation	Description
16	Nebulizer intensity indication	Indicates the selected nebulizer intensity during setting Changes dynamically to indicate ongoing operation
17	Segment display	Indicates the current relative room humidity Indicates the desired relative room humidity during setting Indicates the number of hours during timer programming
18	Night mode indication	Illuminated when night mode is activated
19	Operation indication	Illuminated when the mains plug is connected Illuminated during ongoing operation
20	BABY indication	Illuminated when baby mode is activated
21	Empty water tank indication	Displayed when the water tank is empty
22	ion indication	Illuminated when ionization is activated
23	AUTO indication	Illuminated when automatic mode is activated

Operating elements

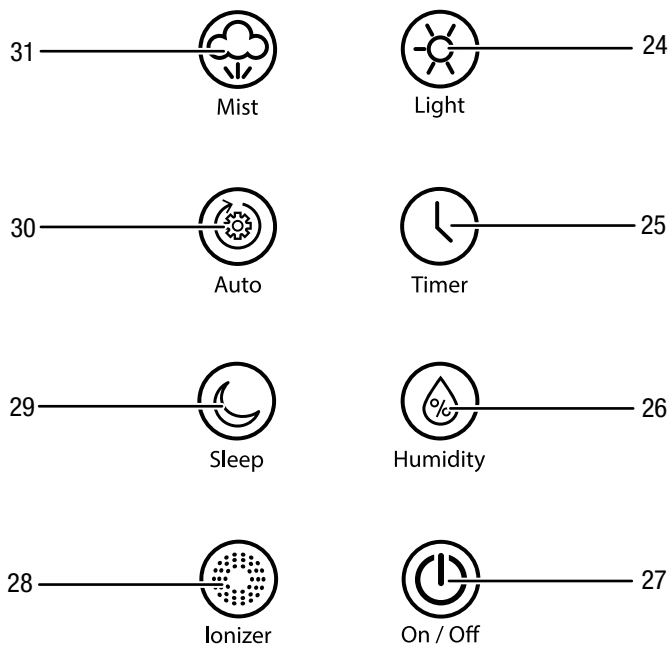

No.	Designation	Description
24	<i>Light</i> button	Switching the blue water tank illumination on or off
25	<i>Timer</i> button	Switching the timer function on or off
26	<i>Humidity</i> button	Setting the relative room humidity
27	<i>On/Off</i> button	Power button: Switching the device on or off
28	<i>Ionizer</i> button	Switching ionization on or off
29	<i>Sleep</i> button	Switching on night mode
30	<i>Auto</i> button	Switching automatic mode or baby mode on
31	<i>Mist</i> button	Setting the nebulizer intensity

Switching the device on

1. Make sure that the tank has been filled with drinking water.
2. Make sure that the device is neither damp nor wet on the outside. Otherwise wipe it dry.
3. Press the *On/Off* button (27).
⇒ The device starts to humidify. Fine water mist leaves the mist nozzle (14).
4. You can rotate the mist nozzle (14) 360° to adjust the outlet direction of the water mist.



Info

Do not remove the water tank during operation. Otherwise, the device will continue operation and water mist may be sprayed out uncontrollably and lead to unintentional precipitation of moisture around the device.

Controlling humidification

The desired room humidity can be set to 40 %, 50 %, 60 % or *OL* (continuous humidification regardless of the room humidity).

1. Press the *Humidity* button (26) until the desired room humidity is displayed.
⇒ The desired room humidity flashes on the segment display (17) for approx. 5 s.
⇒ Then, the current relative room humidity is shown on the segment display (17) again.
⇒ The desired relative room humidity is set.

Setting the nebulizer intensity

The nebulizer intensity can be set in manual humidification mode. The default setting is level 2.

The nebulizer intensity can be set to 3 levels:

- level 1 = low nebulizer intensity
- level 2 = medium nebulizer intensity
- level 3 = high nebulizer intensity

1. Press the *Mist* button (31).
⇒ The current nebulizer intensity flashes on the nebulizer intensity indication (16).
2. Press the *Mist* button (31) again until the desired nebulizer intensity is set.
3. Wait until the nebulizer intensity indication (16) stops flashing and dynamically indicates operation again.
⇒ The desired nebulizer intensity is set.

Setting the operating mode

Manual humidification

The device always starts in this operating mode. The current room humidity and nebulizer intensity are shown on the display.

The desired relative room humidity can be adjusted at any time in this operating mode. The setting options are 40 %, 50 %, 60 % or *OL* (continuous humidification regardless of the room humidity).

The nebulizer intensity can be adjusted at any time in this operating mode.

- If the current relative room humidity is lower than the desired relative room humidity, the device humidifies the air with the selected nebulizer intensity.
- If the current relative room humidity is equal to or higher than the desired relative room humidity, the device humidifies the air at nebulizer intensity level 1.
- If *OL* is selected, the device humidifies the air with the selected nebulizer intensity regardless of the current relative room humidity.

Automatic mode

The device humidifies the air constantly and regardless of the relative room humidity.

The desired relative room humidity and the nebulizer intensity cannot be adjusted in this operating mode.

In automatic mode, the device operates with the following settings:

- If the current relative room humidity is equal to or higher than 60 %, the device humidifies the air at nebulizer intensity level 1.
- If the current relative room humidity is between 40 % and 60 %, the device humidifies the air at nebulizer intensity level 2.
- If the current relative room humidity is below 40 %, the device humidifies the air at nebulizer intensity level 3.

1. Press the *Auto* button (30).
 - ⇒ The *AUTO* indication (23) is displayed.
 - ⇒ The device operates in automatic mode.
2. Press the *Sleep* button (29) to switch over to night mode, or the *Auto* button (30) to switch over to baby mode.

Baby mode

The device humidifies the air constantly to create a room humidity level that is pleasant for babies.

The desired relative room humidity and the nebulizer intensity cannot be adjusted in this operating mode.

In baby mode, the device operates with the following settings:

- If the current relative room humidity is higher than 60 %, the device humidifies the air at nebulizer intensity level 1.
- If the current relative room humidity is between 55 % and 60 %, the device humidifies the air at nebulizer intensity level 2.
- If the current relative room humidity is below 55 %, the device humidifies the air at nebulizer intensity level 3.

1. Press the *Auto* button (30) until the *BABY* indication (20) appears on the display.
 - ⇒ The device operates in baby mode.
2. Press the *Sleep* button (29) to switch over to night mode, or the *Auto* button (30) to switch over to automatic mode.

Night mode

The device humidifies the air constantly and regardless of the relative room humidity.

The timer is automatically set to 8 h.

The desired relative room humidity and the nebulizer intensity cannot be adjusted in this operating mode.

The display switches off after approx. 5 s and only switches back on when a button is pressed. Please note that pressing the *On/Off* button (27) switches the device off.

In night mode, the device operates with the following settings:

- If the current relative room humidity is equal to or higher than 60 %, the device humidifies the air at nebulizer intensity level 1.
- If the current relative room humidity is between 40 % and 60 %, the device humidifies the air at nebulizer intensity level 2.
- If the current relative room humidity is below 40 %, the device humidifies the air at nebulizer intensity level 3.

1. Press the *Sleep* button (29).
 - ⇒ The night mode indication (18) is displayed.
 - ⇒ The device operates in night mode.
2. Press the *Auto* button (30) to switch over to automatic mode.

Setting the timer

For the device to switch off automatically after a predefined number of hours (up to max. 12 h) you can programme the timer.

In night mode, the timer is automatically set to 8 h.

The timer can be programmed in increments of 1 hour (1 to 12 h) in manual humidification mode, automatic mode and baby mode.

Please proceed as follows to programme automatic switch-off:

1. Press the *Timer* button (25).
 - ⇒ The number of hours flashes on the segment display (17).
2. Press the *Timer* button (25) until the desired number of hours is displayed.
3. Wait a moment until the number of hours stops flashing.
 - ⇒ The timer setting equals the desired number of hours.
 - ⇒ The current room humidity is displayed again.
 - ⇒ The device switches off after the set period of time.

Note regarding automatic switch-off:

- Pressing the *On/Off* button (27) deactivates the automatic switch-off function.
- Changing the operating mode deactivates automatic switch-off.
- If you select 0 hours, the automatic switch-off will be deactivated.
- The timer stops when the empty water tank indication (21) lights up. The timer continues to run as soon as the water tank is full again.

Switching illumination on or off

The water tank can be additionally illuminated by 4 blue LEDs in the lower part of the device.

1. Press the *Light* button (24) to switch the illumination on or off.

Switching ionization on or off

Ionization can be switched on as needed. The device will then release ions for additional air purification. The released ions remove pollen, dust, viruses and bacteria from the room air.

Ionization can be switched on in any operating mode.

1. Press the *Ionizer* button (28) to switch ionization on or off.
 - ⇒ When ionization is activated, the *ion* indication (22) will be shown on the display.

Shutdown



Warning of electrical voltage

Do not touch the mains plug with wet or damp hands.

- Switch off the device.
- Hold onto the mains plug while pulling the power cable out of the mains socket.
- Empty the water tank.
- Empty the lower part.
- Use a cloth to wipe all parts of the device dry.
- Clean the device according to the Maintenance chapter.
- Store the device according to the Storage chapter.

Available accessories



Warning

Only use accessories and additional equipment specified in the operating manual. Using insertion tools or accessories other than those specified in the operating manual may cause a risk of injury.

Designation	Article number
SecoSan® Stick 10	6.100.004.110

Errors and faults

The device has been checked for proper functioning several times during production. If malfunctions occur nonetheless, check the device according to the following list.

The device does not start:

- Check the power connection.
- Check the power cable and mains plug for damage.
- Check the on-site fusing.
- Check whether the water tank indicator light is illuminated. The water tank might be empty and need refilling.
- Wait for 10 minutes before restarting the device. If the device is not starting, have the electricians checked by a specialist company or by Trotec.

The device is running, but there is no formation of mist:

- Check whether the water tank indicator light is illuminated. The water tank might be empty and need refilling.
- Check the valve in the water tank lid. The valve must be able to move freely. If necessary, clean the water tank.
- Check the float in the lower part of the device. The float should be able to move freely.
- Check the air filter for dirt. If necessary, clean the air filter.
- Check the nebulizer intensity setting and increase it if required.
- Check the nebulizer membrane in the lower part of the device for dirt and clean it if required.

The water tank is full, but the device indicates an empty water tank:

- Heavy deposits on the filter cartridge may prevent the water from flowing from the water tank into the device. This can occur if the device has been out of use for a long time. Rinse the filter cartridge with clear water and, if required, carefully clean the filter at the filter cartridge.
- Check the valve in the water tank lid. The valve must be able to move freely. If necessary, clean the water tank.

Water is leaking:

- Check whether the device is set up in a stable and upright position.
- Check the water level in the lower part of the device. The water level might be too high and water is discharged via the overflow.
- Check the valve in the water tank lid. The valve must be able to move freely. If necessary, clean the water tank.
- Check the float in the lower part of the device. The float should be able to move freely. It may block and cause water to be discharged via the overflow.
- Check the device for leaks.

The water mist has a peculiar smell:

- The device is new. Remove and rinse the water tank. Let the open water tank air for some hours.
- Check the water tank. There may be stale or dirty water in the water tank. Rinse the water tank and fill it with fresh drinking water.

Condensate forms on the device:

- The air circulation in the room is insufficient. If necessary, reduce the nebulizer intensity and provide better air circulation (e.g. using a fan).
- The room's humidity level is quite high. This makes it difficult for the mist to distribute and leads to water condensing on the device. If necessary, reduce the nebulizer intensity or switch off the device.

The device is loud or vibrates heavily:

- Check whether the device is set up in a stable and upright position.

The device keeps running without the water tank:

- This is a perfectly normal process. Switch the device off before removing the water tank.

Your device still does not operate correctly after these checks?

Please contact the customer service. If necessary, bring the device to an authorised specialist electrical company or to Trotec for repair.

Maintenance

Maintenance intervals

Maintenance and care interval	before every start-up	as needed	every 3 days	at least every 2 weeks	at least every 4 weeks	at least every 6 months	at least annually
Clean the water tank			X				
Check air inlets and outlets for dirt and foreign objects and clean if necessary	X				X		
Clean the exterior		X					X
Visually check the inside of the device for dirt		X					X
Check the air filter for dirt and foreign objects and clean or replace if necessary	X			X			
Replace the air filter						X	
Check for damage	X						
Check attachment screws		X					X
Test run							X

Maintenance and care log

Device type:

Device number:

Maintenance and care interval	1	2	3	4	5	6	7	8	9	10	11	12	13	14	15	16
Clean the water tank																
Check air inlets and outlets for dirt and foreign objects and clean if necessary																
Clean the exterior																
Visually check the inside of the device for dirt																
Check the air filter for dirt and foreign objects and clean or replace if necessary																
Air filter replacement																
Check for damage																
Check attachment screws																
Test run																

1. Date: Signature:	2. Date: Signature:	3. Date: Signature:	4. Date: Signature:
5. Date: Signature:	6. Date: Signature:	7. Date: Signature:	8. Date: Signature:
9. Date: Signature:	10. Date: Signature:	11. Date: Signature:	12. Date: Signature:
13. Date: Signature:	14. Date: Signature:	15. Date: Signature:	16. Date: Signature:

Activities required before starting maintenance



Warning of electrical voltage

Do not touch the mains plug with wet or damp hands.

- Switch the device off.
- Hold onto the mains plug while pulling the power cable out of the mains socket.



Warning of electrical voltage

Tasks which require the housing to be opened must only be carried out by authorised specialist companies or by Trotec.

Safety signs and labels on the device

Check the safety signs and labels attached to the device at regular intervals. Replace illegible safety signs!

Cleaning the housing

Clean the housing with a soft, damp and lint-free cloth. Ensure that no moisture enters the housing. Protect electrical components from moisture. Do not use any aggressive cleaning agents such as cleaning sprays, solvents, alcohol-based or abrasive cleaners to dampen the cloth.

Cleaning the water tank



Info

Use the SecoSan® Stick by Trotec to provide protection from germs in the water. The SecoSan® Stick prevents the reproduction of germs by means of silver ions. Due to the special, antimicrobial surface, the silver ions are emitted to the immediate proximity of bacteria and germs. This way, microbial growth can be effectively prevented – at the same time, the water remains pure and uncontaminated. The dosage of the SecoSan® Stick is carried out automatically.

The water tank should be cleaned every 3 days if actively used. Use household vinegar as cleaning/descaling agent. Observe the manufacturer's specifications and hazard warnings of the descaling agent. Before a longer period of non-use or storage the water tank should be drained.

1. Remove the water tank (2) from the device by lifting the water tank at the transport handle (1).
Note that there may still be residual water left in the lower part (3) if the device was used beforehand.

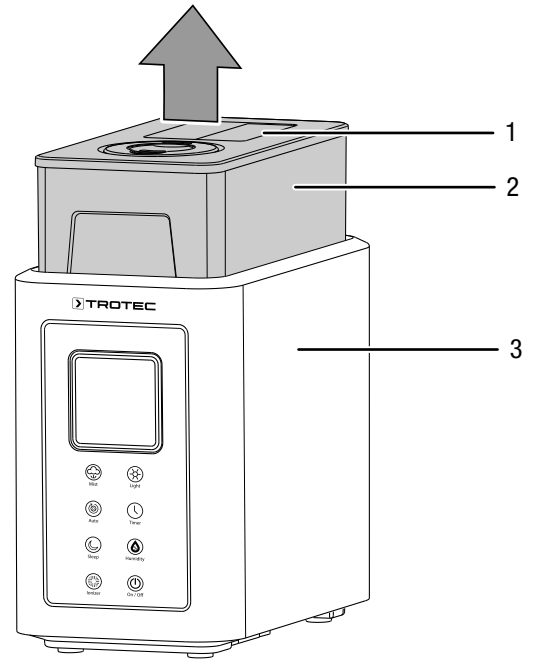

2. Remove the mist nozzle (14) from the water tank.

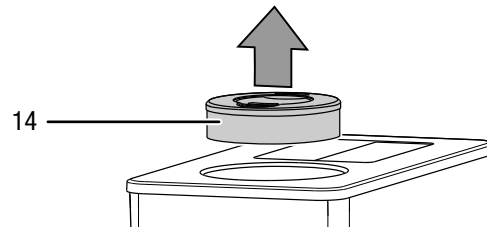

3. Turn the water tank over.
4. Unscrew the lid (15) from the water tank (2).

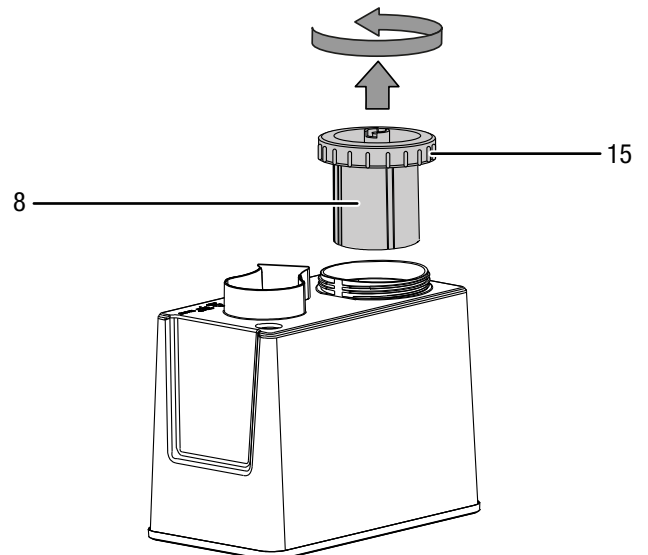

5. Drain the residual water from the water tank.

6. Take the SecoSan® Stick out of the water tank (1).
7. Thoroughly rinse the water tank with household vinegar (descaling agent).
8. Thoroughly rinse the water tank and the SecoSan® Stick with clear water.
9. Allow the water tank to dry.
10. Clean the inside of the bottom section and the mist nozzle with household vinegar (descaling agent) and then use a lint-free cloth to wipe the parts dry.
For cleaning the nebulizer membrane, see chapter *Cleaning the nebulizer membrane*.
11. Insert the SecoSan® Stick into the water tank (1).
12. Fill the water tank with fresh drinking water.
13. If required, screw the filter cartridge with water softener (8) onto the lid (15).
14. Screw the lid (15) firmly back onto the water tank (2).

16. Refit the water tank (2) into the device.
In doing so, make sure that the arrow points to the front. Please note that after inserting the water tank, the water starts to run into the inside of the device immediately.

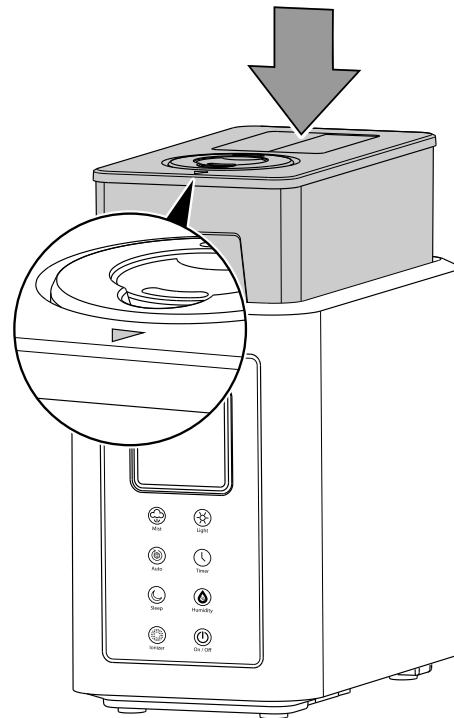

Cleaning the nebulizer membrane

Depending on the hardness of the drinking water used, deposits may form on the nebulizer membrane over time. These could affect the nebulizer performance. Therefore, the nebulizer membrane should be cleaned on a regular basis.

To do so, please proceed as follows:

1. Remove the water tank (2) and the mist nozzle (14) as described in *Cleaning the water tank*.
2. Remove any residual water from the inside of the device.
3. Wet the nebulizer membrane (9) with household vinegar (descaling agent).
4. Let the descaling agent act for approx. 2 to 5 min.

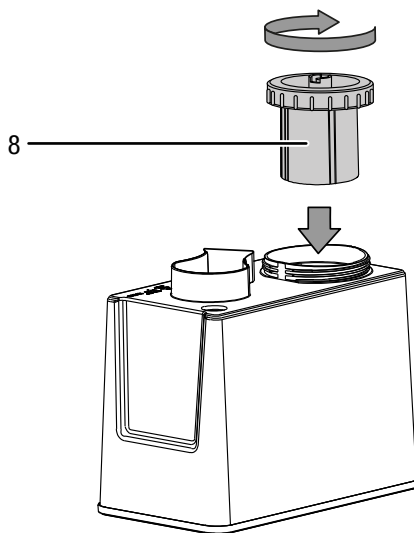

15. Refit the mist nozzle (14) onto the water tank (2).

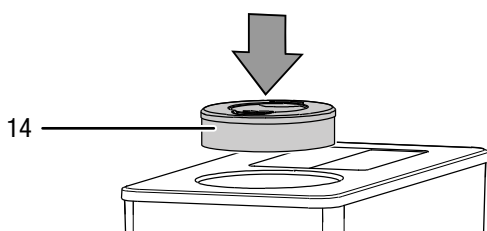

- Remove the deposits from the nebulizer membrane (9) using the brush (11).

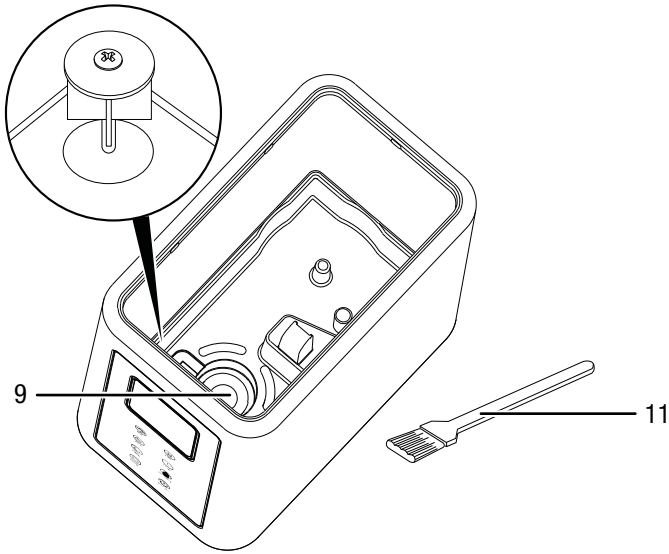

- Rinse the inside of the device with clear water.
- Refit the water tank (2) and the mist nozzle (14) as described in *Cleaning the water tank*.

Regenerating the water softener

Depending on the hardness of the water, the water softener must be regenerated approx. once per month.

To do so, please proceed as follows:

- Remove the water tank (2) and the mist nozzle (14) as described in *Cleaning the water tank*.
- Unscrew the lid (15) from the water tank (2).

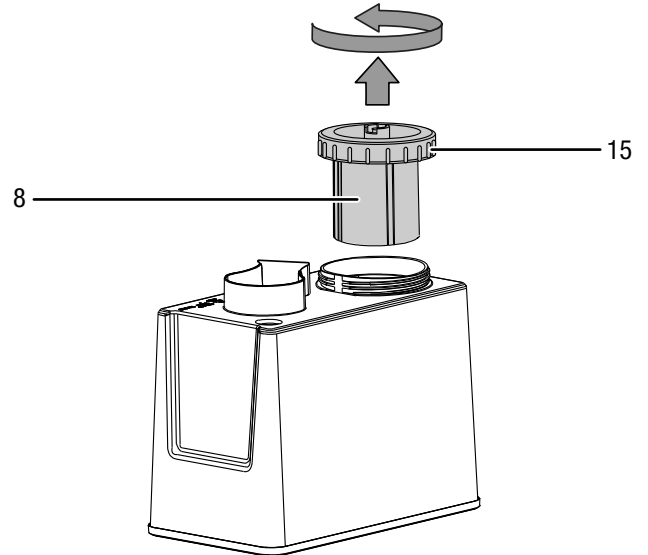

- Unscrew the filter cartridge (8) from the lid (15).
- Provide a vessel containing saturated saline solution.
- Place the filter cartridge into the vessel containing saline solution. Make sure that the filter cartridge is completely covered by the saline solution.
- Leave the filter cartridge in the saline solution for 24 h.
- Take the filter cartridge out of the saline solution after 24 h.
- Rinse the filter cartridge with clear water.
- Screw the filter cartridge (8) back onto the lid (15).
- Screw the lid (15) firmly back onto the water tank (2).

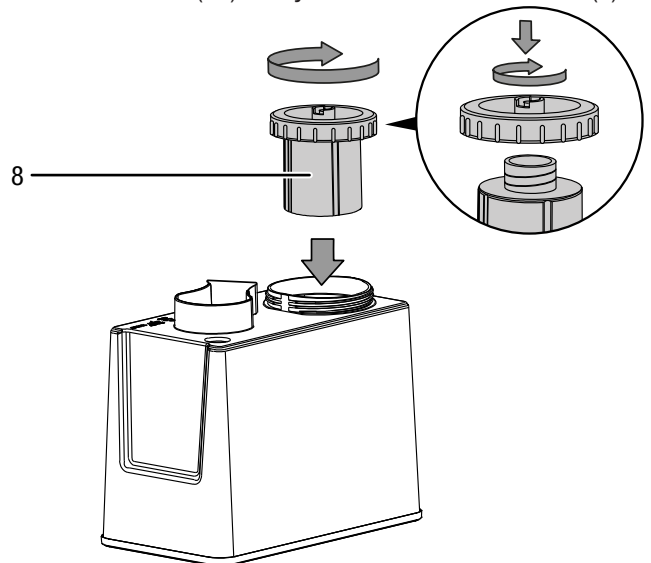

- Refit the water tank (2) and the mist nozzle (14) as described in *Cleaning the water tank*.

Cleaning the air filter

Note

Ensure that the air filter is not worn or damaged. The corners and edges of the air filter must not be deformed or rounded. Before reinserting the air filter, make sure that it is undamaged and dry!

The air filter has to be cleaned as soon as it is dirty. This is brought to light e.g. by a reduced capacity (see chapter Errors and faults).

1. Remove the air filter from the device.

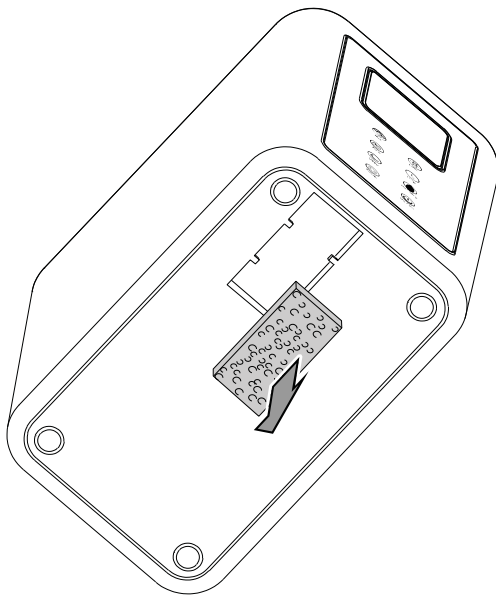

Activities required after maintenance

If you want to continue using the device:

- Reconnect the device to the mains.

If you do not intend to use the device for a considerable time:

- Store the device according to the Storage chapter.

Technical annex

Technical data

Parameter	Value
Model	B 5 E
Nebulizer performance	300 ml/h
Runtime	13 h
Power consumption	25 W
Mains connection	220 V – 240 V / 50 – 60 Hz
Nominal current consumption	0.1 A
Plug type	CEE 7/16
Cable length	1.5 m
Sound pressure level (1 m distance)	37 dB (A)
Water tank capacity	4 l
Weight	3 kg
Dimensions (length x width x height)	285 x 175 x 290 (mm)

2. Rinse the filter with warm water.
3. Allow the filter to dry completely. Do not insert a wet filter into the device!
4. Reinsert the air filter into the device.

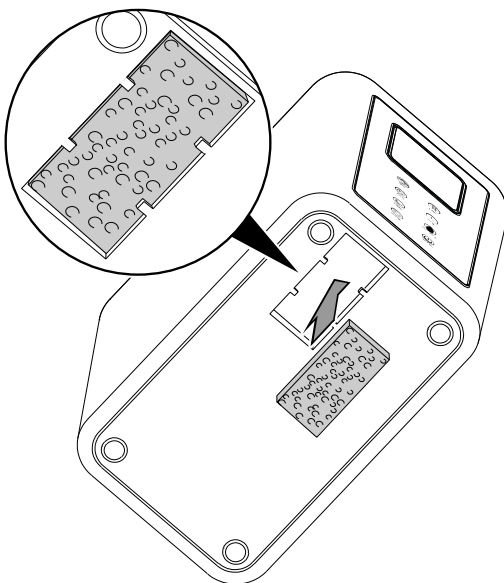

Trotec GmbH

Grebener Str. 7
D-52525 Heinsberg

☎ +49 2452 962-400

☎ +49 2452 962-200

✉ info@trotec.com

www.trotec.com