

IDE 20 D / IDE 30 D / IDE 50 D / IDE 60 D / IDE 100 D

EN

ORIGINAL INSTRUCTIONS
OIL HEATER



Table of contents

Information on the use of these instructions 2

Safety 3

Information about the device..... 5

Transport and storage..... 7

Assembly and start-up..... 7

Operation 10

Errors and faults..... 11

Available accessories 12

Maintenance 13





Technical annex..... 15

Disposal 29

Declaration of conformity 29

Information on the use of these instructions

Symbols

-  **Warning of electrical voltage**
This symbol indicates dangers to the life and health of persons due to electrical voltage.
-  **Warning of flammable substances**
This symbol indicates dangers to the life and health of persons due to flammable substances.
-  **Warning of hot surface**
This symbol indicates dangers to the life and health of persons due to hot surface.
-  **Warning**
This signal word indicates a hazard with an average risk level which, if not avoided, can result in serious injury or death.
-  **Caution**
This signal word indicates a hazard with a low risk level which, if not avoided, can result in minor or moderate injury.
- Notice**
This signal word indicates important information (e.g. material damage), but does not indicate hazards.



Info

Information marked with this symbol helps you to carry out your tasks quickly and safely.



Follow the manual

Information marked with this symbol indicates that the instructions must be observed.



Wear hearing protection

Information marked with this symbol indicates that you should wear hearing protection.

You can download the current version of these instructions via the following link:

IDE 20 D



<https://hub.trotec.com/?id=41240>

IDE 30 D



<https://hub.trotec.com/?id=41241>

IDE 50 D



<https://hub.trotec.com/?id=41242>

IDE 60 D



<https://hub.trotec.com/?id=41243>

IDE 100 D



<https://hub.trotec.com/?id=41239>



Safety

Read this manual carefully before starting or using the device. Always store the manual in the immediate vicinity of the device or its site of use.



Warning

Read all safety warnings and all instructions.

Failure to follow the warnings and instructions may result in electric shock, fire and/or serious injury.

Save all warnings and instructions for future reference.

This device must not be used by children and persons under 16 years of age.

Children shall not play with the appliance. Cleaning and user maintenance shall not be made by children under 16 years.



Warning

Do not use the device in rooms if persons are present who cannot leave the room independently and who are not under constant supervision.

- Do not use the device in potentially explosive rooms or areas and do not install it there.
 - Do not use the device in aggressive atmosphere.
 - Place the device in an upright and stable position on horizontal and stable ground.
 - Let the device dry out after a wet clean. Do not operate it when wet.
 - Do not use the device with wet or damp hands.
 - Do not expose the device to directly squirting water.
 - Never insert any objects or limbs into the device.
 - Do not cover the device during operation.
 - Do not remove any safety signs, stickers or labels from the device. Keep all safety signs, stickers and labels in legible condition.
 - Attention: In Germany, the Federal Emission Protection Directive applies. Do not operate the device for more than 3 months at the same place. Prior to planning the flue gas system, gather information about the national legislation and contact a responsible specialist.
 - Do not sit on the device.
 - This appliance is not a toy. Keep away from children and animals.
 - Check accessories and connection parts for possible damage prior to every use of the device. Do not use any defective devices or device parts.
 - Ensure that all electric cables outside of the device are protected from damage (e.g. caused by animals). Never use the device if electric cables or the power connection are damaged!
- The mains connection must correspond to the specifications in the Technical annex.
 - Insert the mains plug into a properly fused mains socket.
 - Observe the device's power input, cable length and intended use when selecting extensions to the power cable. Completely unroll extension cables. Avoid electrical overload.
 - Before carrying out maintenance, care or repair work on the device, remove the mains plug from the mains socket. Hold onto the mains plug while doing so.
 - Switch the device off and disconnect the power cable from the mains socket when the device is not in use.
 - Do not under any circumstances use the device if you detect damages on the mains plug or power cable. If the power cable is damaged, it must be replaced by the manufacturer, its service agent or similarly qualified persons in order to avoid a hazard. Defective power cables pose a serious health risk!
 - When positioning the device, observe the minimum distances from walls and other objects as well as the storage and operating conditions specified in the Technical annex.
 - Make sure that the air inlet and outlet are not obstructed.
 - Make sure that the suction side is kept free of dirt and loose objects.
 - Do not place the device on combustible ground.
 - Only transport the device in an upright position.
 - Only use original spare parts, for otherwise safe and functional operation cannot be ensured.
 - Do not use the heating device together with a programming device, a timer, a separate remote control system or any other device that automatically switches the heating device on, as there is a risk of fire if the heating device is covered or incorrectly positioned.

Intended use

The device was developed for the purpose of generating hot air and may only be used in roofed over outdoor areas or in well-ventilated interior spaces whilst adhering to the technical data.

The device is suited for heating large rooms such as tents, warehouses, workshops, construction sites, greenhouses or agricultural halls.

It is intended to be used without frequent site changes.

The device may only be used in rooms with sufficient fresh air supply and exhaust discharge.

The device must only be operated with EL (ultra-light) fuel oil, kerosene and diesel, however not with petrol, heavy fuel oil etc.

Any use other than the intended use is regarded as misuse.

Reasonably foreseeable misuse

- Do not place any objects, e.g. clothing, on the device.
- Do not use this device in the vicinity of fuel, solvents, varnishes or other easily inflammable vapours or in rooms where these substances are stored.
- Do not use the device in areas with a fire hazard or in potentially explosive areas.
- Do not use the heating device in immediate proximity to swimming pools.
- Do not use the device out of doors, unless under a roof.
- Do not operate the device in rooms without sufficient combustion air supply.
- Never immerse the device in water.
- Do not make any unauthorised modifications, alterations or structural changes to the device.

Personnel qualification

People who use this device must:

- be aware of the dangers resulting from heat, fire hazard and insufficient ventilation when working with oil heaters.
- be aware of the dangers that occur when handling fuels such as EL fuel oil, diesel or kerosene
- have read and understood the instructions, especially the Safety chapter.

Personal protective equipment



Wear hearing protection

Wear appropriate hearing protection when working with the device.

Residual risks



Warning of electrical voltage

Work on the electrical components must only be carried out by an authorised specialist company!



Warning of electrical voltage

Before any work on the device, remove the mains plug from the mains socket!

Do not touch the mains plug with wet or damp hands. Hold onto the mains plug while pulling the power cable out of the mains socket.



Warning of flammable substances

Handling fuels entails a risk of fire.

Take sufficient precautions when handling fuels such as EL fuel oil, diesel or kerosene.

Do not spill any fuels! Do not inhale the vapours nor swallow any fuel! Avoid skin contact!



Warning of hot surface

Parts of the device, especially at the air outlet, become very hot during operation. There is a danger of burning and fire. Do not touch the device during operation!

During operation observe a safety distance of at least 2 m to the device front! Observe the minimum distance from walls or other objects according to the technical data!



Warning of hot surface

Parts of this appliance can become very hot and cause burns. Particular attention is to be paid when there are children or vulnerable persons present!



Warning of hot surface

Improper handling entails a risk of burning. Use this appliance only as described in this operating instructions.



Warning

Improper handling entails a risk of burning and electric shock.

Only use the device as intended!



Warning

Dangers can occur at the device when it is used by untrained people in an unprofessional or improper way! Observe the personnel qualifications!



Warning

The device is not a toy and does not belong in the hands of children.



Warning

Risk of suffocation!

Do not leave the packaging lying around. Children may use it as a dangerous toy.



Warning

Improper installation entails a risk of fire.
Do not place the device on combustible ground.
Do not place the device on high-pile carpets.



Warning

The device must not be covered, there is an imminent fire hazard!

Behaviour in the event of an emergency

1. In an emergency, disconnect the device from the mains feed-in: Switch the device off and disconnect it from the mains.
2. Remove persons from the danger area.
3. Do not reconnect a defective device to the mains.

Overheating protection

The device is provided with a safety thermostat which is activated by overheating of the device (when exceeding the operating temperature).

Investigate the cause of overheating.

If the safety thermostat does not switch in the event of overheating, the overheating protection will be tripped. In that case the device switches off completely. If so, please contact the customer service to have the overheating protection replaced.

Information about the device

Device description

The directly fired oil heaters IDE 20 D, IDE 30 D, IDE 50 D, IDE 60 D and IDE 100 D serve the purpose of heating the room air so as to quickly heat large, well-ventilated rooms. The oil heaters run on EL fuel oil, kerosene or diesel, they must not be used with petrol, heavy fuel oil etc.

The devices are oil heaters with direct combustion to be installed in roofed outdoor areas or in rooms with a sufficient fresh air supply. The device IDE 100 D is further equipped with a Danfoss pump.

All devices are protected against splash water (IPX4).

Functional principle

The device generates warmth by conveying the sucked-in, cold air past a combustion chamber. Inside the combustion chamber the fuel is burned. The sucked-in air is heated and fed back to the environment via the air outlet.

A part of the sucked-in air is compressed and conducted to the injection. The fuel is fed from the tank to the injection by the negative pressure thus created. An ignition contact at the injection ignites the fuel, which is then burned in a continuous flame.

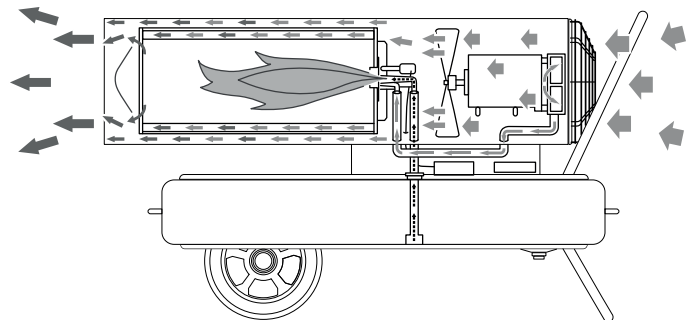

Device depiction

IDE 20 D

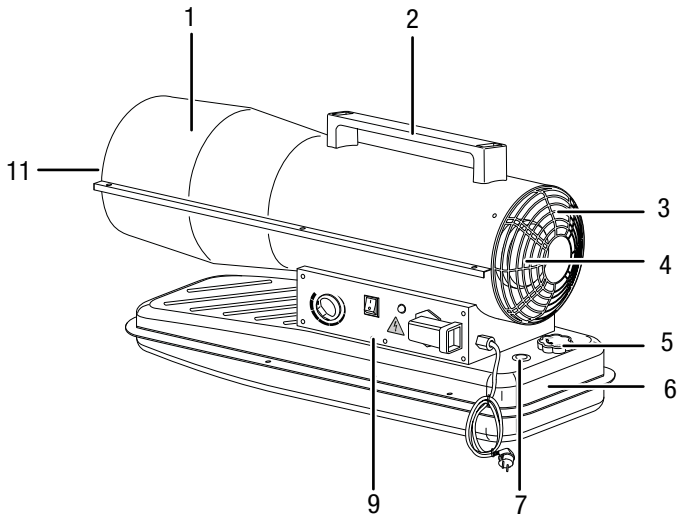

IDE 30 D

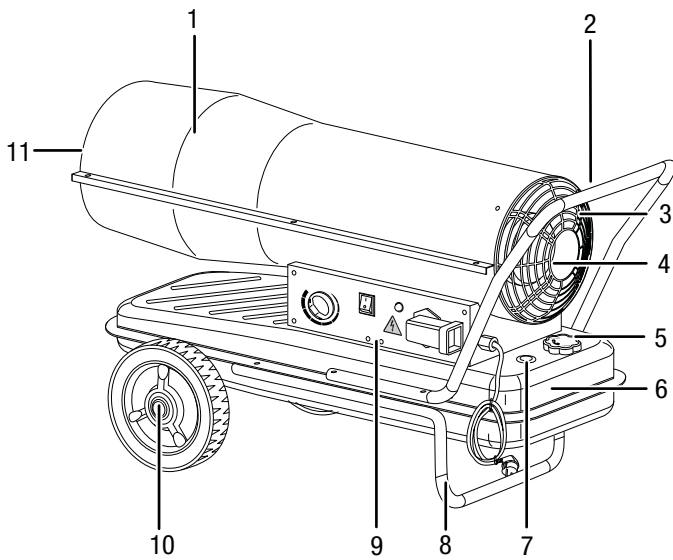

IDE 50 D / IDE 60 D

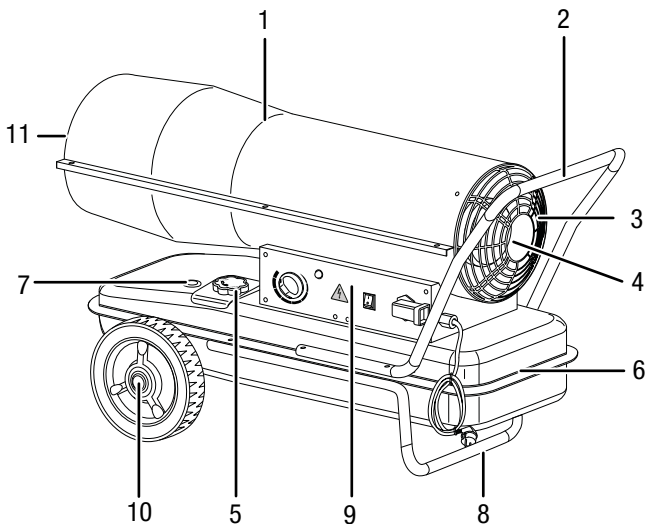

IDE 100 D

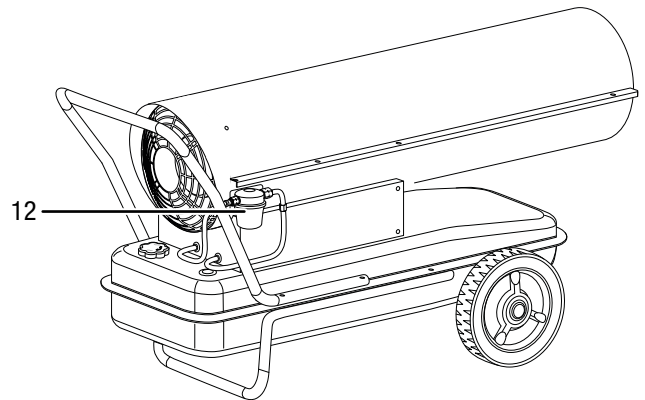
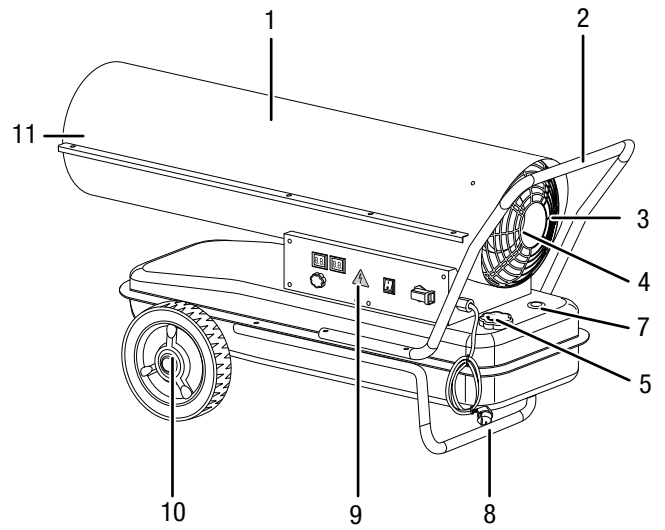

No.	Designation
1	Combustion chamber housing
2	Transport handle
3	Air inlet with protective grid
4	Fan and motor
5	Fuel tank cap
6	Tank
7	Tank filling level indication
8	Frame
9	Control panel
10	Wheel
11	Air outlet for hot air
12	Fuel filter (IDE 100 D only)

Transport and storage

Notice

If you store or transport the device improperly, the device may be damaged.

Note the information regarding transport and storage of the device.

Transport

To make the device easier to transport, it is fitted with wheels.

To make the device easier to transport, it is fitted with a carry handle.

Before transporting the device, observe the following:

- Switch the device off.
- Hold onto the mains plug while pulling the power cable out of the mains socket.
- Do not use the power cable to drag the device.
- Allow the device to cool down sufficiently.

While transporting the device, observe the following:

IDE 20 D

- Only transport the IDE 20 D by use of the transport handle (2).

IDE 30 D / IDE 50 D / IDE 60 D / IDE 100 D

- Slightly lift the device by the transport handle (2) until the rear support no longer touches the ground.
- Wheel the device to the desired position.

Storage

Before storing the device, proceed as follows:

- Hold onto the mains plug while pulling the power cable out of the mains socket.
- Allow the device to cool down sufficiently.

When the device is not being used, observe the following storage conditions:

- Store the device in a dry location and protected from frost and heat.
- Store the device in an upright position where it is protected from dust and direct sunlight.
- If required, use a cover to protect the device from invasive dust.

Assembly and start-up

Scope of delivery

- 1 x Oil heater
- 1 x Carry handle (IDE 20 D only)
- 1 x Frame components (IDE 30 D / IDE 50 D / IDE 60 D / IDE 100 D only)
- 2 x Wheel (IDE 30 D / IDE 50 D / IDE 60 D / IDE 100 D only)
- 1 x Installation material
- 1 x Manual

Unpacking the device

1. Open the cardboard box and take the device out.
2. Completely remove the packaging.
3. Fully unwind the power cable. Make sure that the power cable is not damaged and that you do not damage it during unwinding.

Assembly

Upon delivery the device is already partially preassembled.

In case of the devices IDE 30 D / 50 D / 60 D and 100 D, the wheels, axle, frame and transport handle still need to be mounted.

Assembling the wheels (IDE 30 D / 50 D / 60 D / 100 D)

Prior to initial start-up, the wheels and the axle must be attached to the frame. To do so, please proceed as follows:

1. Slide the axle through the openings at the frame.

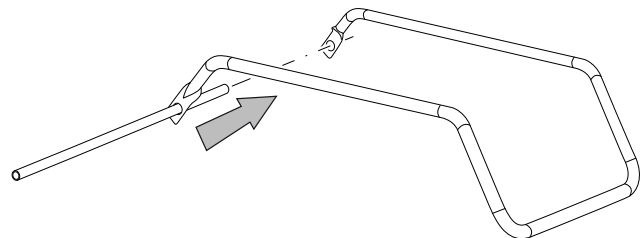

2. Attach both wheels to the axle.
3. Attach the locking rings to the axle.
4. Fasten the wheel caps to the wheels.

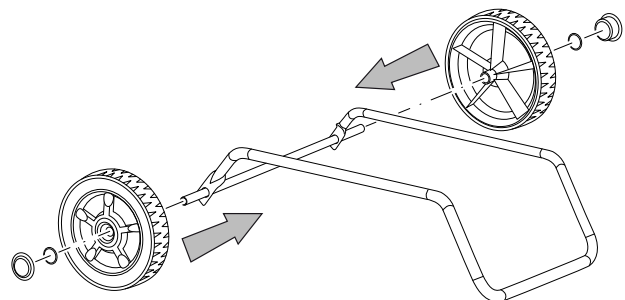

Info

If necessary, the frame can be disassembled again (e.g. for storage). To remove the wheels from the axle, you can carefully loosen the locking rings by means of a slotted screwdriver.

Assembly of transport handle and frame (IDE 30 D / 50 D / 60 D / 100 D)

1. Place the device on the frame. Make sure that the holes for the screws are positioned flush above each other.
2. First, bolt the 4 small screws to the frame.
3. Screw the nuts to the screws from below.
4. Place the transport handle on the rear section.
5. Bolt the 4 large screws to the transport handle, device and frame.

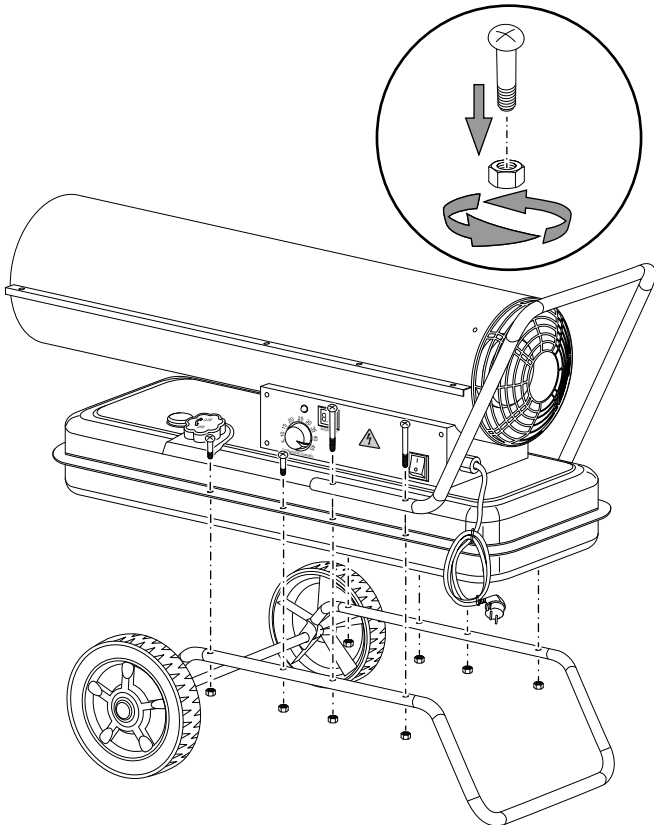

Positioning

A number of spatial and technical conditions have to be considered for the selection of the device's installation site. Non-observance may impair the proper functioning of the device or the accessories or can entail risks of personal injury and property damage.

The following is to be observed for positioning:

- Do not operate the device for more than 3 months at the same place. Prior to planning the flue gas system, gather information about the national legislation and contact a responsible specialist.
- The device may only be operated on roofed over surfaces.
- The device is to be set up in a stable position on incombustible ground.
- The device must be set up in close proximity to a flue, an outer wall or on an open, ventilated surface.
- The device must be connected to a properly secured mains power socket.
- The room where the device is positioned must be sufficiently ventilated.

Ensure a sufficient fresh air supply, especially when there are people or animals in the same room with the device!

- The minimum distance between walls or other objects and the air outlet opening of the device must be at least 3 m (see figure).

The minimum distance between walls or other objects and the air inlet opening of the device must be at least 2 m (see figure).

There must be no walls or large objects near the device.

- The inlet and outlet openings must not be covered.
- There must be a sufficient number of fire extinguishers available.

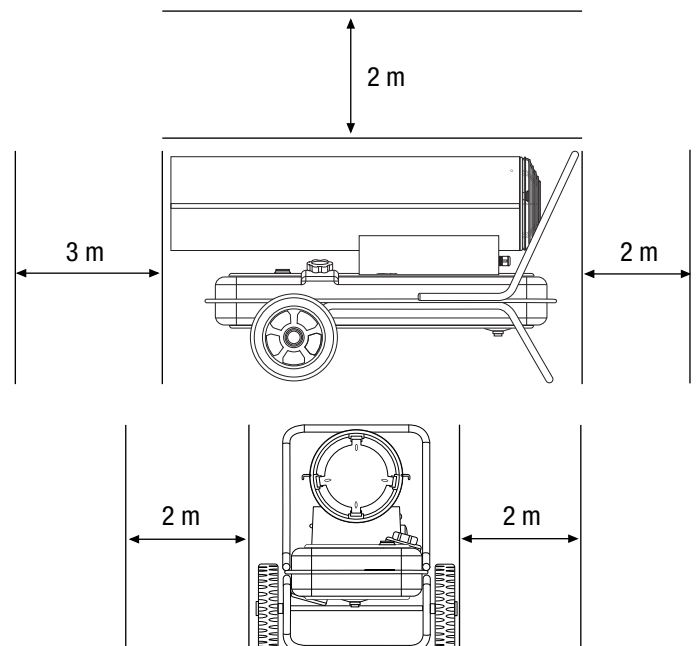

Start-up

- Check the scope of delivery of your device for completeness. If an accessory part is missing, please contact the Trotec customer service or the specialist dealer where you purchased the device.
- Check the device and its connection parts for potential damage.
- Observe the conditions described in the chapter Positioning.
- Fill the tank with EL fuel oil, kerosene or diesel as described in chapter Assembly
- Check the device for its proper condition prior to start-up and at regular intervals during application.
- Check whether the characteristics of the power grid conform to those on the nameplate.
- Each time before you plug the mains plug into the mains socket and switch on the device, make sure that the fan is moving freely.
- Connect the power cable to a properly secured socket. On construction sites, there must be a residual current device (RCD) upstream of the socket in accordance with national regulations (in Germany: VDE 0100/0105).

The device is now ready for operation.

Filling the tank



Warning of flammable substances

In order to prevent fires, make sure that there are no ignition sources near the tank.

The tank cover and the filling level indication of the IDE 20 D / IDE 30 D are located at the rear of the device, those of the IDE 50 D / IDE 60 D / IDE 100 D are located on the left side of the control panel. The images in the description below show the IDE 100 D by way of example.

✓ Before attempting to fill the tank, wait until the device has cooled down completely.

✓ Only use fuel suitable for the device (see technical data).

1. Position the device on firm, level and incombustible ground.

2. Unscrew the fuel tank cap (5).

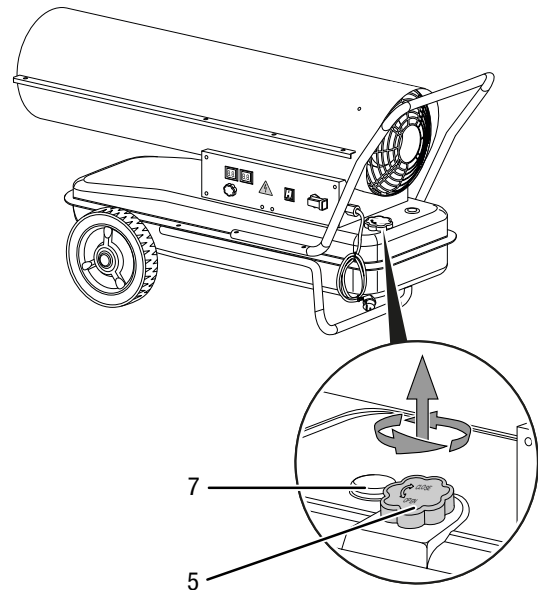

3. Fill the tank. In doing so, observe the filling level indication (7). Stop filling the tank just before the red range.
4. Screw the fuel tank cap (5) back onto the tank. Observe the recesses at the tank opening and the protrusions at the fuel tank cap. They must be aligned when attaching the fuel tank cap. Make sure that the fuel tank cap is firmly attached to avoid leakage.

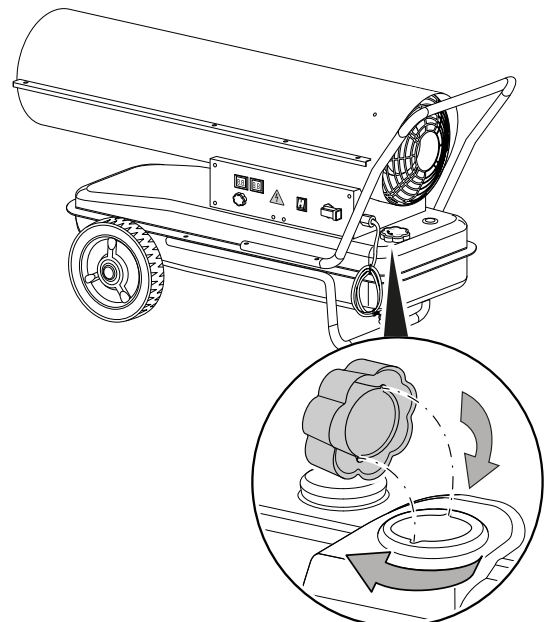

Operation

The device may only be used by accordingly instructed persons.

Operating elements

IDE 20 D / IDE 30 D

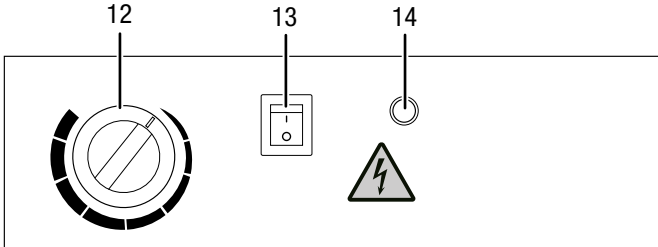

IDE 50 D

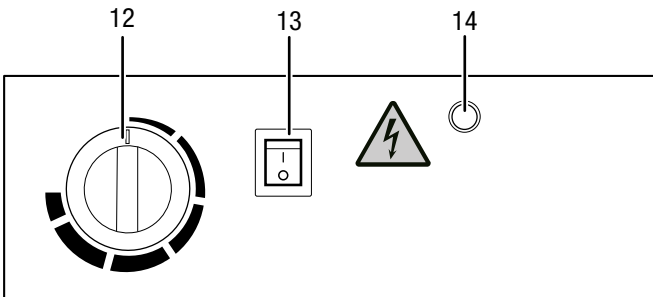

IDE 60 D

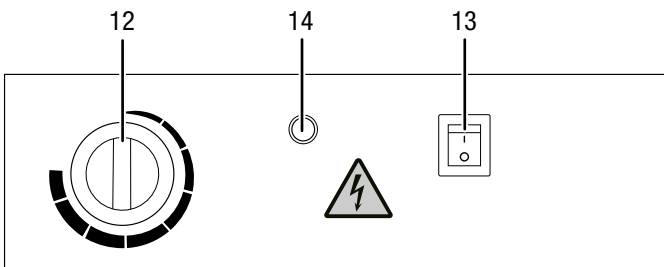

IDE 100 D

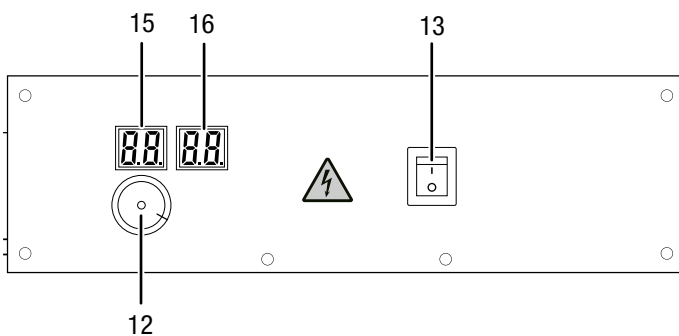

No.	Designation
12	Rotary control thermostat
13	On/off switch
14	Operating LED
15	Target value indication
16	Room temperature indication

Switching the device on



Wear hearing protection.

Excessive noise can lead to hearing loss.

The device continues to operate until the desired room temperature is reached.

1. Set the on/off switch (13) to position **I**.
⇒ The on/off switch (13) is illuminated.
2. Set the rotary control (12) to the desired room temperature. This value should be higher than the current room temperature.
3. Ensure a successful ignition.

Shutdown



Warning of electrical voltage

Do not touch the mains plug with wet or damp hands.

Notice

Damage to the device due to overheating!

Never switch off the device by pulling the mains plug.

This may lead to overheating!

Switch off the device properly. Only remove the mains plug from the device once the fan motor has stopped completely.

1. Switch off the device by setting the on/off switch (13) to position **0**.
⇒ The on/off switch (13) is no longer illuminated.
2. Wait until the fan motor has come to a complete standstill.
3. Secure the device against inadvertent switch-on by pulling the mains plug.
4. Allow the device to cool down completely.

Restart after troubleshooting

During initial start-up and after the fuel oil circuit has been drained completely, the fuel oil supply to the nozzle may be insufficient. In this case, the flame monitoring system will respond and the device will be blocked. Please proceed as follows:

1. Wait for approx. 1 minute.
2. Switch the device on.

If the device is still not starting, proceed as follows:

1. Make sure that there is fuel left in the tank.
2. Please refer to the chapters General safety warnings and Errors and faults.

Errors and faults



Warning of electrical voltage

Tasks which require the device to be opened must only be carried out by authorised specialist companies or by the manufacturer.



Warning

Risk of injury due to improper repair!
Never try to make any modifications or repairs on the device.
Unauthorised modifications can lead to serious injuries or death.
Have a certified specialist workshop perform the repair work.

Notice

Wait for at least 3 minutes after maintenance and repair work. Only then switch the device back on.

The device has been checked for proper functioning several times during production. If malfunctions occur nonetheless, check the device according to the following list.

The device does not start:

- Check the power connection.
- Check the power cable and mains plug for damage. If you notice damages, do not try to take the device back into operation.
If the supply cord is damaged, it must be replaced by the manufacturer, its service agent or similarly qualified persons in order to avoid a hazard.
- Check the on-site fusing.

Smoke and/or sparks are emitted during first use:

- This is not a fault. These phenomena disappear after a brief runtime.

Noise emission during ignition or cooling:

- This is not a fault. The metal parts of the device expand when heated and generate noise.

Sparks and/or flames are issued from the device's front or rear during ignition:

- This is not a fault. Air might have accumulated in the lines. Keep a safety distance to the openings of the device!

The flame in the combustion chamber does not ignite:

- Check the filling level of the tank. Refill fuel if the tank is empty (see Filling the tank).
- Check the fuel filter and the fuel pump for dirt. If it is dirty, please contact the customer service.
- Check the fuel for contaminations, e.g. dirt or water. If required, drain the fuel completely and fill in new and clean fuel (see Filling the tank).

- Safety shutdown: if the flame dies during operation, the electronics and the oil pump will be switched off. Investigate the cause on the basis of the following criteria:

– For qualified personnel only!

Check the ignition: The distance between the two ignition electrodes should be 4 to 5 mm.

The flame goes out during combustion:

- Make sure the air supply is unobstructed. If required, clean the air intake opening.
- Check the filling level of the tank. Refill fuel if the tank is empty (see Filling the tank).
- Check the fuel filter and the fuel pump for dirt. If it is dirty, please contact the customer service.
- Check the fuel for contaminations, e.g. dirt or water. If required, drain the fuel completely and fill in new and clean fuel (see Filling the tank).
- Power failure: In the event of a power failure the ignition is extinguished, the device switches off immediately. After a power failure the device will not restart automatically, it has to be started via the on/off switch.

There is a fuel leak:

- Check whether too much fuel was filled in. Drain the fuel if necessary, see chapter Draining the tank.
- Check the drain screw for tight fit and retighten it if necessary.
- Check the sealing at the drain screw and replace it if damaged.
- Check the fuel pump for leaks. If there are doubts about the proper condition of the fuel pump, please contact the customer service.

The device emits smoke or dust:

- Check the fuel for contaminations, e.g. dirt or water. If required, drain the fuel completely and fill in new and clean fuel (see Filling the tank).

The flame emerges from the air outlet:

- Check the fuel for contaminations and replace it if required.
- Check the tank for contaminations and drain it if required (see chapter Maintenance). Refill with clean fuel.

The device still does not operate correctly after these checks:

Please contact the customer service. If necessary, bring the device to an authorised specialist electrical company or to the manufacturer for repair.

Available accessories

Accessories	IDE 20 D Article number	IDE 30 D Article number	IDE 50 D Article number	IDE 60 D Article number	IDE 100 D Article number
External thermostat with 25 m cable	6.100.006.113	6.100.006.113	6.100.006.113	6.100.006.113	6.100.006.113
Connection kit for external oil tank	-	6.100.006.183	6.100.006.183	6.100.006.183	6.100.006.183
Adapter set tank kit – oil hose	-	7.210.000.003	7.210.000.003	7.210.000.003	7.210.000.003
Tank line with quick couplings, length 5 m	-	6.100.006.037 ¹	6.100.006.037 ¹	6.100.006.037 ¹	6.100.006.037 ¹
Fuel tank, 1,000 litres	-	6.100.006.011	6.100.006.011	6.100.006.011	6.100.006.011
Fuel tank, 3,000 litres	-	6.100.006.012	6.100.006.012	6.100.006.012	6.100.006.012

¹ in combination with adapter set tank kit – oil hose (required accessories)



Warning

Only use accessories and additional equipment specified in the instructions.
Using insertion tools or accessories other than those specified in the instructions may cause a risk of injury.

Maintenance

Maintenance intervals

Maintenance and care interval	before every start-up	as needed	at least every 2 weeks	at least every 4 weeks	at least every 6 months	at least annually
Check air inlets and outlets for dirt and foreign objects and clean if necessary	X					
Check air inlet grid(s) for dirt and foreign objects and clean if necessary	X		X			
Clean the exterior		X				X
Visually check the inside of the device for dirt		X		X		
Check for damage	X					
Check the attachment screws		X				X
Test run						X

Maintenance and care log

Device type:

Device number:

Maintenance and care interval	1	2	3	4	5	6	7	8	9	10	11	12	13	14	15	16
Check air inlets and outlets for dirt and foreign objects and clean if necessary																
Check air inlet grid(s) for dirt and foreign objects and clean if necessary																
Clean the exterior																
Visually check the inside of the device for dirt																
Check for damage																
Check the attachment screws																
Test run																
Comments																

1. Date:	2. Date:	3. Date:	4. Date:
Signature:	Signature:	Signature:	Signature:
5. Date:	6. Date:	7. Date:	8. Date:
Signature:	Signature:	Signature:	Signature:
9. Date:	10. Date:	11. Date:	12. Date:
Signature:	Signature:	Signature:	Signature:
13. Date:	14. Date:	15. Date:	16. Date:
Signature:	Signature:	Signature:	Signature:

Activities required before starting maintenance



Warning of electrical voltage

Do not touch the mains plug with wet or damp hands.

- Switch the device off.
- Hold onto the mains plug while pulling the power cable out of the mains socket.
- Allow the device to cool down completely.



Warning of electrical voltage

Tasks which require the device to be opened must only be carried out by authorised specialist companies or by the manufacturer.

Cleaning the housing

Clean the housing with a soft, damp and lint-free cloth. Make sure that no moisture enters the housing. Protect electrical components from moisture. Do not use any aggressive cleaning agents such as cleaning sprays, solvents, alcohol-based or abrasive cleaners to dampen the cloth.

Wipe the housing dry after cleaning.

Draining the tank



Warning of flammable substances

In order to prevent fires, make sure that there are no ignition sources near the tank.

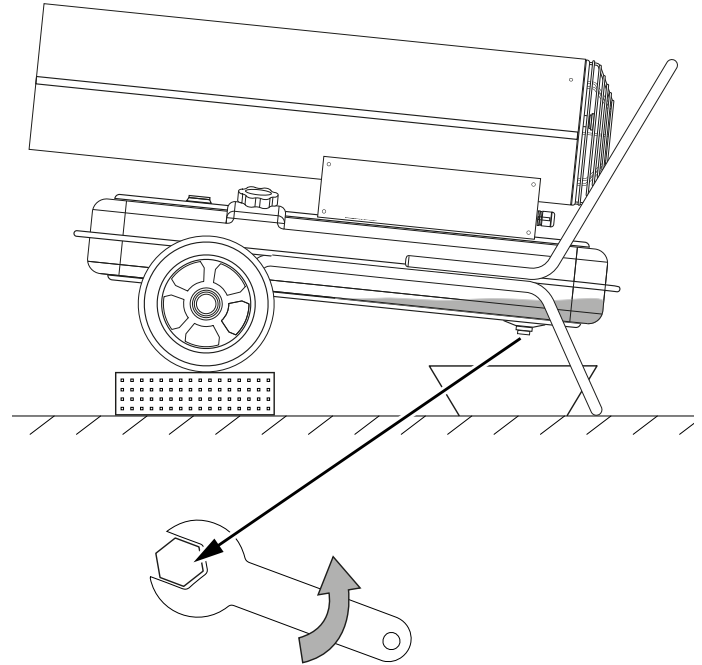

1. Provide for a suitable collection container.
2. Move the device to an elevated position.
3. As indicated in the figure use a wrench to open the screw at the bottom of the tank.
4. Drain the fuel into the collection container.
5. When no more fuel is discharged, seal the drain hole again.
 - ⇒ Ensure the tight fit of the screw and, if required, replace the seal, for otherwise fuel might leak out uncontrollably.
6. Dispose of the fuel according to national regulations.

Technical annex
Technical data

Parameter	Value				
Model	IDE 20 D	IDE 30 D	IDE 50 D	IDE 60 D	IDE 100 D
Combustion	direct	direct	direct	direct	direct
Air flow rate	550 m ³ /h	720 m ³ /h	750 m ³ /h	1100 m ³ /h	1300 m ³ /h
Fan	axial fan	axial fan	axial fan	axial fan	axial fan
Nominal heat output	20 kW	30 kW	51 kW	60 kW	100 kW
Ventilation / air changes per hour	at least 2 ACH	at least 2 ACH	at least 2 ACH	at least 2 ACH	at least 2 ACH
Operating temperature	-20 °C to +40 °C	-20 °C to +40 °C	-20 °C to +40 °C	-20 °C to +40 °C	-20 °C to +40 °C
Relative humidity during operation	max. 90 % RH	max. 90 % RH	max. 90 % RH	max. 90 % RH	max. 90 % RH
Storage conditions	-20 °C to +40 °C with 20 % to 80 % RH	-20 °C to +40 °C with 20 % to 80 % RH	-20 °C to +40 °C with 20 % to 80 % RH	-20 °C to +40 °C with 20 % to 80 % RH	-20 °C to +40 °C with 20 % to 80 % RH
Temperature increase ΔT	140 °C	210 °C	180 °C	150 °C	350 °C
Max. fuel consumption	1.9 l/h	2.8 l/h	4.8 l/h	5.7 l/h	9.5 l/h
Tank capacity	12 l	19 l	38 l	56 l	69 l
Input voltage	230 V / 50 Hz	230 V / 50 Hz	230 V / 50 Hz	230 V / 50 Hz	220 – 240 V / 50 Hz
Current consumption	0.71 A	1.25 A	1.25 A	1.5 A	2.7 A
Overheating protection	yes	yes	yes	yes	yes
Connection for external thermostat	yes	yes	yes	yes	yes
Sound level (at a distance of 1 m)	76 dB(A)	76 dB(A)	77 dB(A)	78 dB(A)	80 dB(A)
Type of protection	IPX4	IPX4	-	-	-
Weight (with empty tank)	10 kg	18 kg	22 kg	28.5 kg	41 kg
Dimensions (length x width x height)	650 x 265 x 395 mm	830 x 430 x 560 mm	860 x 456 x 600 mm	1140 x 550 x 680 mm	1210 x 582 x 718 mm
Minimum distance to walls or other objects					
top	2 m	2 m	2 m	2 m	2 m
rear	2 m	2 m	2 m	2 m	2 m
sides	2 m	2 m	2 m	2 m	2 m
front	3 m	3 m	3 m	3 m	3 m
Permitted fuel	EL fuel oil, diesel or kerosene	EL fuel oil, diesel or kerosene	EL fuel oil, diesel or kerosene	EL fuel oil, diesel or kerosene	EL fuel oil, diesel or kerosene



Wear hearing protection.

Excessive noise can lead to hearing loss.

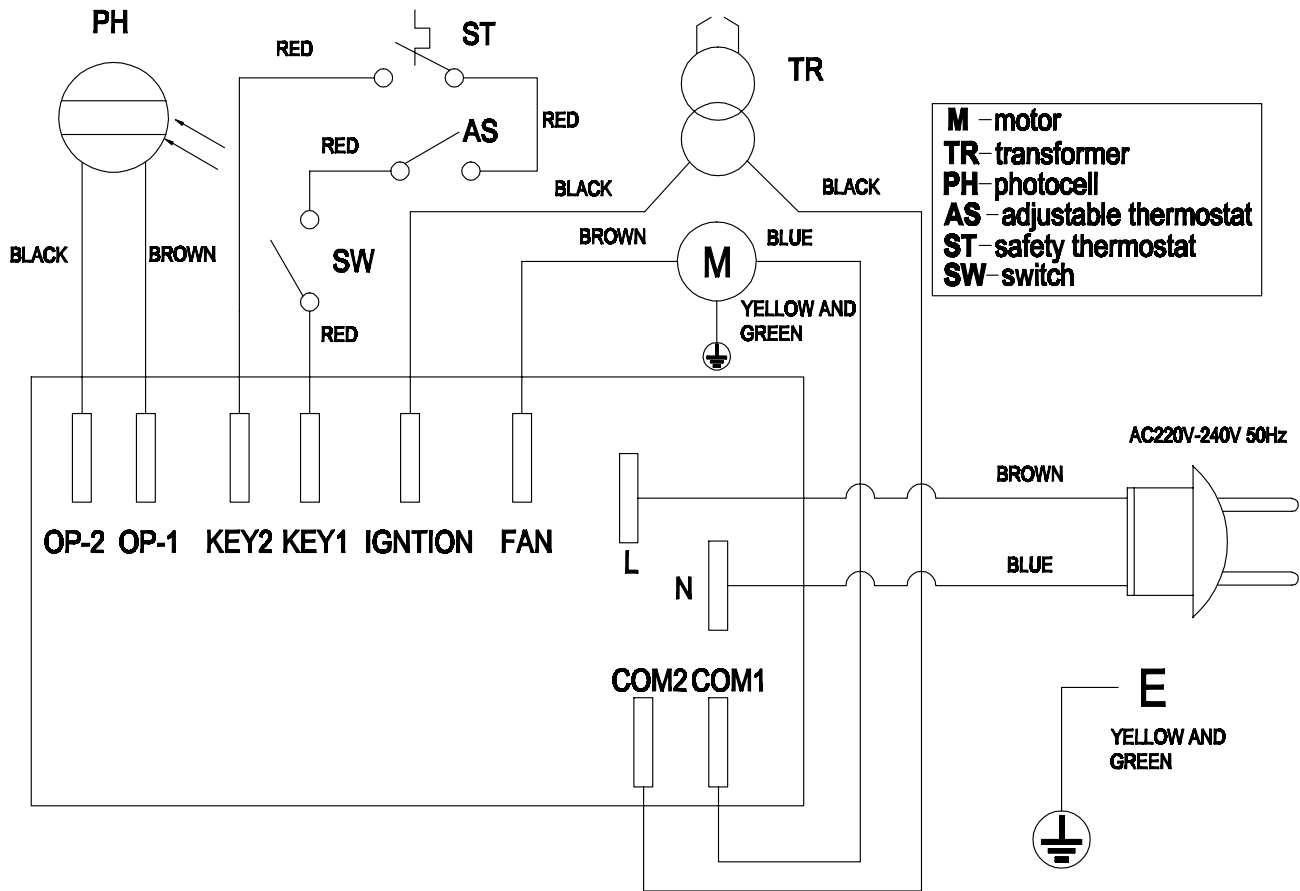
Wiring diagram IDE 20 D / IDE 30 D

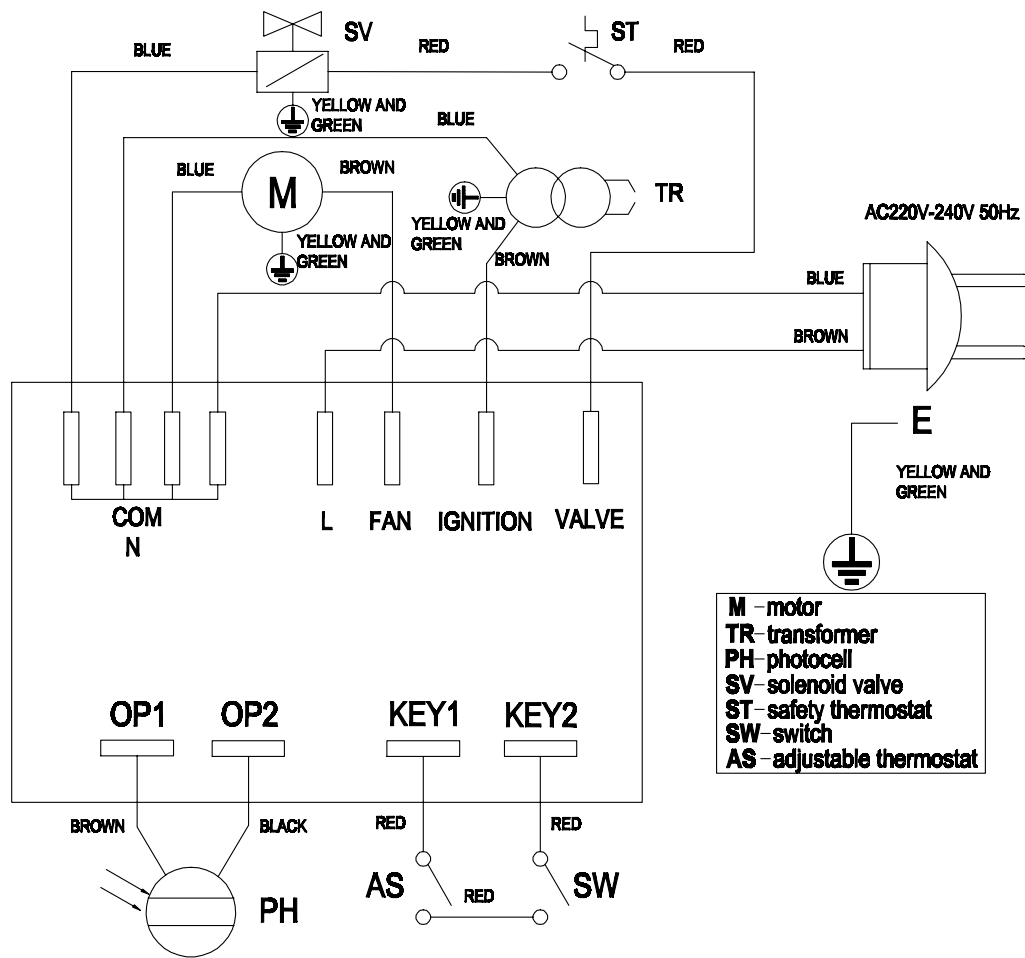

Wiring diagram IDE 50 D / IDE 60 D



Wiring diagram IDE 100 D

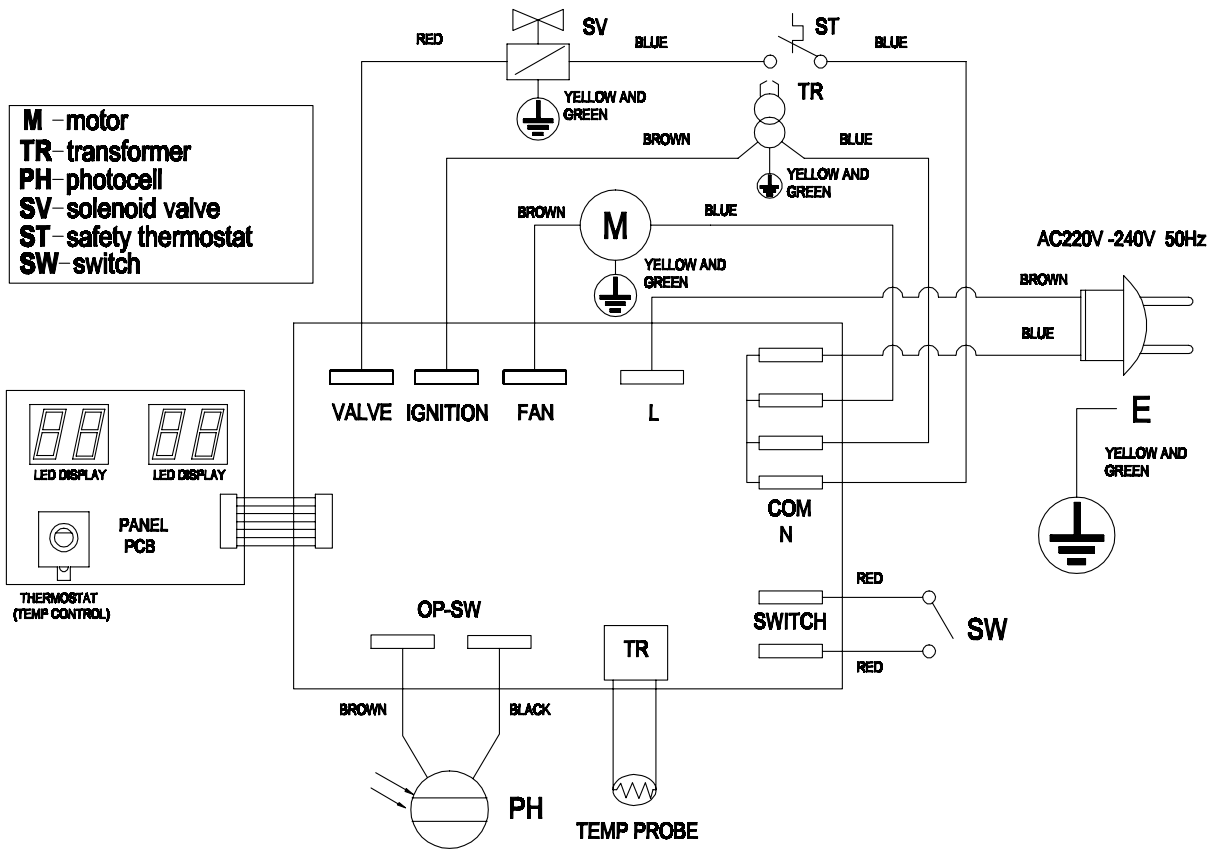

Overview of spare parts IDE 20 D

Note!

The position numbers of the spare parts differ from those describing the positions of the components mentioned in these instructions.

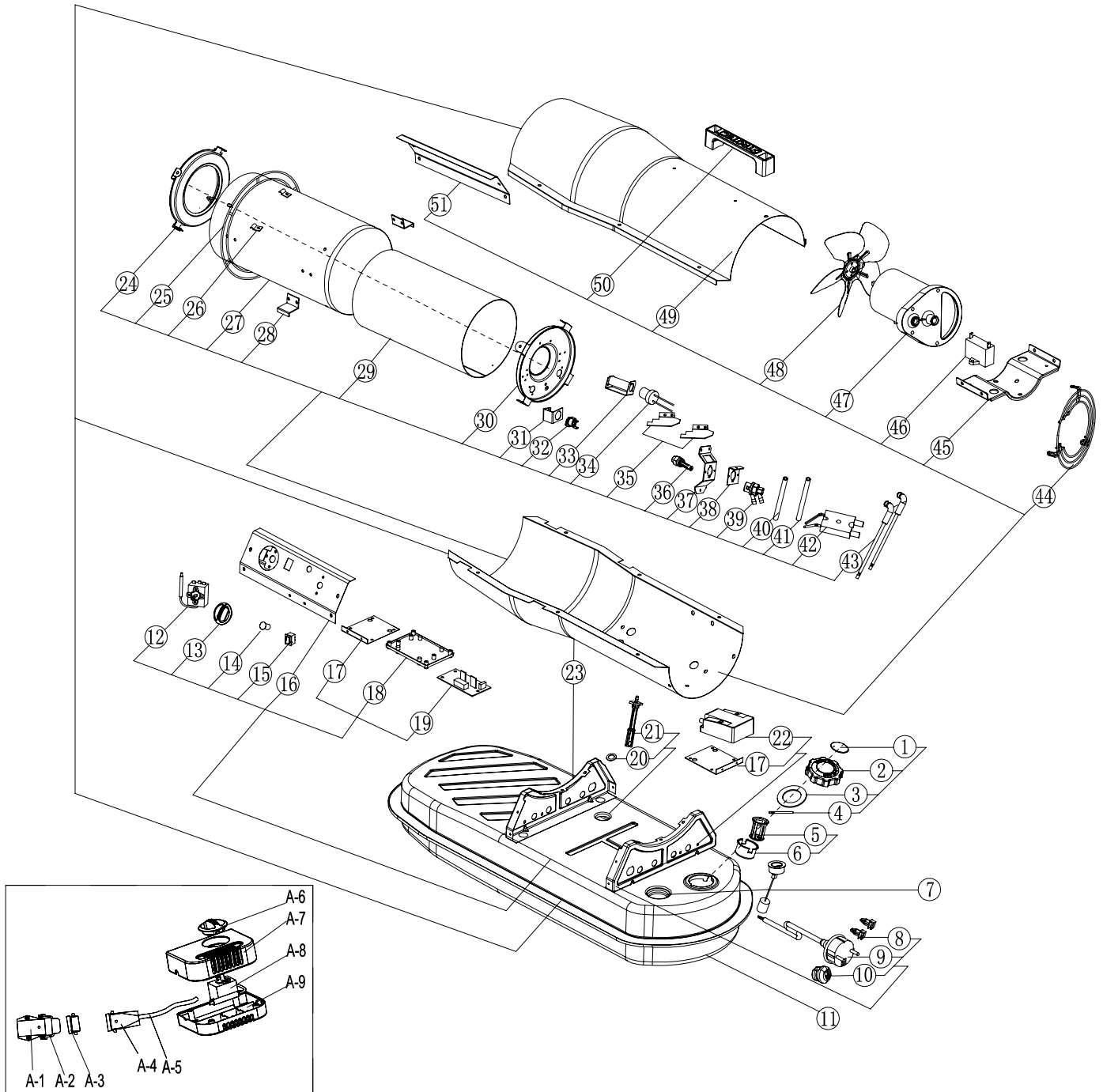

Spare parts list IDE 20 D

NO.	SPARE PART	NO.	SPARE PART	NO.	SPARE PART
1	Breath cover	21	Fuel filter Ass'y	41	Oil hose
2	Fuel tank cap	22	Ignition transformer	42	Ignition needle
3	Sealing ring	23	Bottom cover	43	High voltage cable
4	Tank cap shaft	24	Front cover ass'y	44	Air inlet grill
5	Oil inlet filter	25	Support ring	45	Motor support
6	Oil Inlet filter holder	26	Clamp	46	Capacitor
7	Oil leveler	27	Combustion chamber shield	47	Motor assembly
8	Support	28	Chamber shield bracket	48	Fan
9	Power cord	29	Combustion chamber	49	Top cover
10	Cable fastener	30	Burner support plate	50	Handle
11	Fuel tank	31	Photocell bracket	51	Side panel
12	Adjustable thermostat with probe	32	Re-set thermostat	A-1	Remote control connecter female shell
13	Thermostat knob	33	Photocell assembly bracket	A-2	Buckle
14	Light cover	34	Photocell assembly	A-3	Remote control connecter male cover
15	On/off Switch	35	Air inlet blade	A-4	Remote control connecter male shell
16	Control panel	36	Nozzle assembly	A-5	Line
17	Bracket of ignition transformer	37	Nozzle Adapter Bracket assembly	A-6	Thermostat knob
18	PCB Bracket	38	Ignition needle holder	A-7	Probe protection top cover
19	Power PCB	39	Nozzle Adapter	A-8	Adjustable thermostat with probe
20	Sealing ring	40	Gas hose	A-9	Probe protection bottom cover

Overview of spare parts IDE 30 D

Note!

The position numbers of the spare parts differ from those describing the positions of the components mentioned in these instructions.

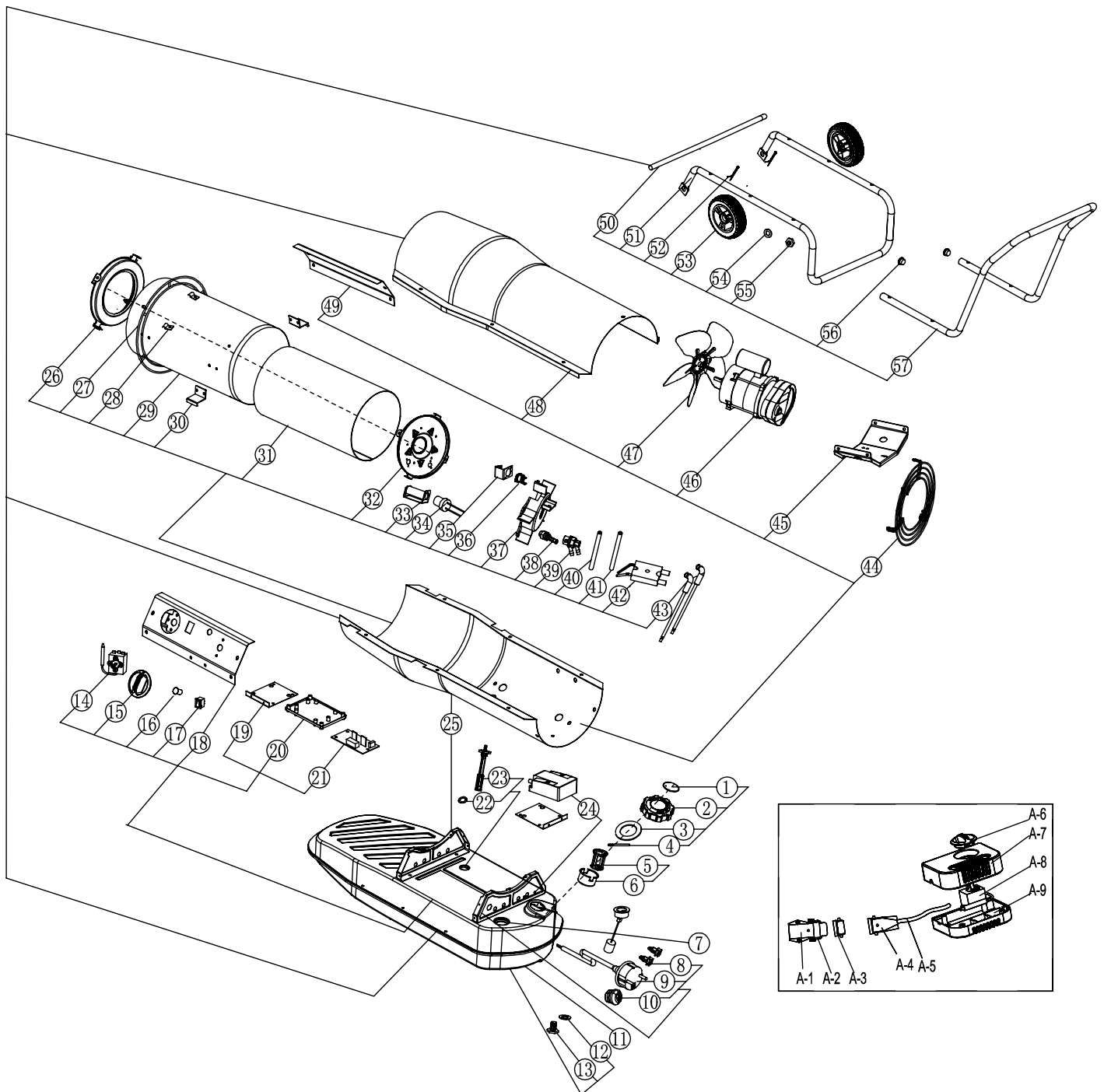

Spare parts list IDE 30 D

NO.	SPARE PART	NO.	SPARE PART	NO.	SPARE PART
1	Breath cover	23	Fuel filter ass'y	45	Motor support
2	Fuel tank cap	24	Ignition transformer	46	Motor assembly
3	Sealing ring	25	Bottom cover	47	Fan
4	Tank cap shaft	26	Front cover ass'y	48	Top cover
5	Oil inlet filter	27	Support ring	49	Side plate
6	Oil inlet filter holder	28	Clamp	50	Wheel axle
7	Oil leveler	29	Combustion chamber shield	51	Feet pipe
8	Support	30	Chamber shield bracket	52	Cotter pin
9	Power cord	31	Combustion chamber	53	Wheel
10	Cable fastener	32	Burner support plate	54	Flat gasket
11	Fuel tank	33	Photocell assembly bracket	55	Screw nut
12	Oil drain sealing ring	34	Photocell assembly	56	Steel pipe plug
13	Oil drain screw	35	Photocell bracket	57	Handle
14	Adjustable thermostat with probe	36	Re-set thermostat	A-1	Remote control connector female shell
15	Thermostat knob	37	Flame plate	A-2	Buckle
16	Light cover	38	Nozzle assembly	A-3	Remote control connector male cover
17	On/off Switch	39	Nozzle Adapter	A-4	Remote control connector male shell
18	Control panel	40	Gas hose	A-5	Line
19	Bracket of ignition transformer	41	Oil hose	A-6	Thermostat knob
20	PCB bracket	42	Ignition needle	A-7	Probe protection top cover
21	Power PCB	43	High voltage cable	A-8	Adjustable thermostat with probe
22	Sealing ring	44	Air inlet grill	A-9	Probe protection bottom cover

Overview of spare parts IDE 50 D

Note!

The position numbers of the spare parts differ from those describing the positions of the components mentioned in these instructions.

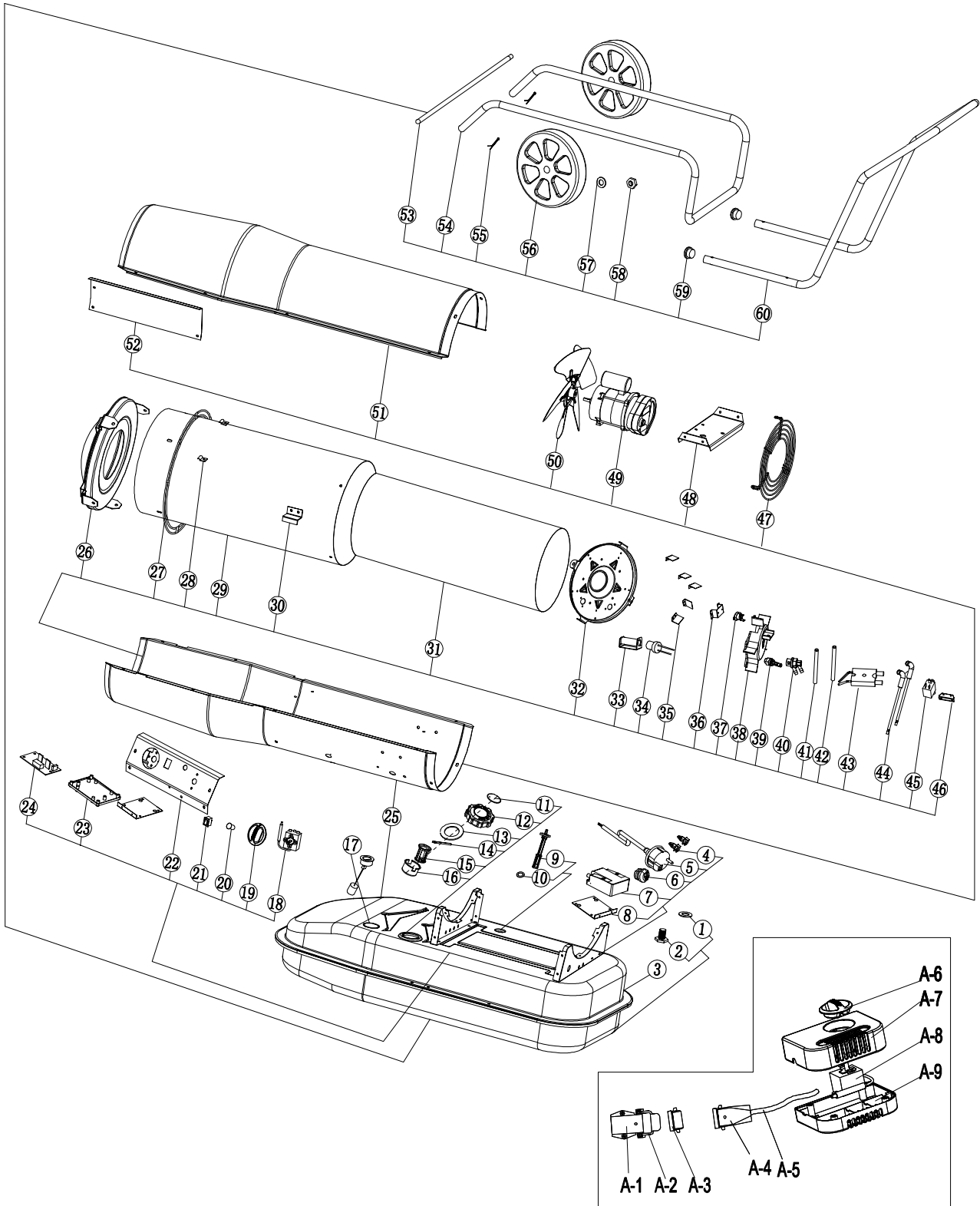

Spare parts list IDE 50 D

NO.	SPARE PART	NO.	SPARE PART	NO.	SPARE PART
1	Oil drain seal ring	24	Power PCB	47	Air inlet grill
2	Oil drain screw	25	Bottom cover	48	Motor support
3	Fuel tank	26	Front cover ass'y	49	Motor assembly
4	Support	27	Support ring	50	Fan
5	Power cord	28	Clamp	51	Top cover
6	Cable fastener	29	Combustion chamber shield	52	Side plate
7	Ignition transformer	30	Chamber shield bracket	53	Wheel axle
8	Bracket of Ignition transformer	31	Combustion chamber	54	Feet pipe
9	Fuel filter ass'y	32	Burner support plate	55	Cotter pin
10	Sealing ring	33	Photocell assembly bracket	56	Wheel
11	Breath cover	34	Photocell assembly	57	Flat gasket
12	Fuel tank cap	35	Blade for combustion chamber	58	Screw nut
13	Sealing ring	36	Re-set thermostat bracket	59	Stell pipe plug
14	Tank cap shaft	37	Re-set thermostat	60	Handle
15	Oil inlet filter	38	Flame palte	A-1	Remote control connecter female shell
16	Oil inlet filter holder	39	Nozzle assembly	A-2	Buckle
17	Oil leveler	40	Nozzle Adapter	A-3	Remote control connecter male cover
18	Adjustable thermostat with probe	41	Gas hose	A-4	Remote control connecter male shell
19	Thermostat knob	42	Oil hose	A-5	Line
20	Light cover	43	Ignition needle	A-6	Thermostat knob
21	On/off switch	44	High voltage cable	A-7	Probe protection top cover
22	Control panel	45	Solenoid valve	A-8	Adjustable thermostat with probe
23	PCB bracket	46	Solenoid valve bracket	A-9	Probe protection bottom cover

Overview of spare parts IDE 60 D

Note!

The position numbers of the spare parts differ from those describing the positions of the components mentioned in these instructions.

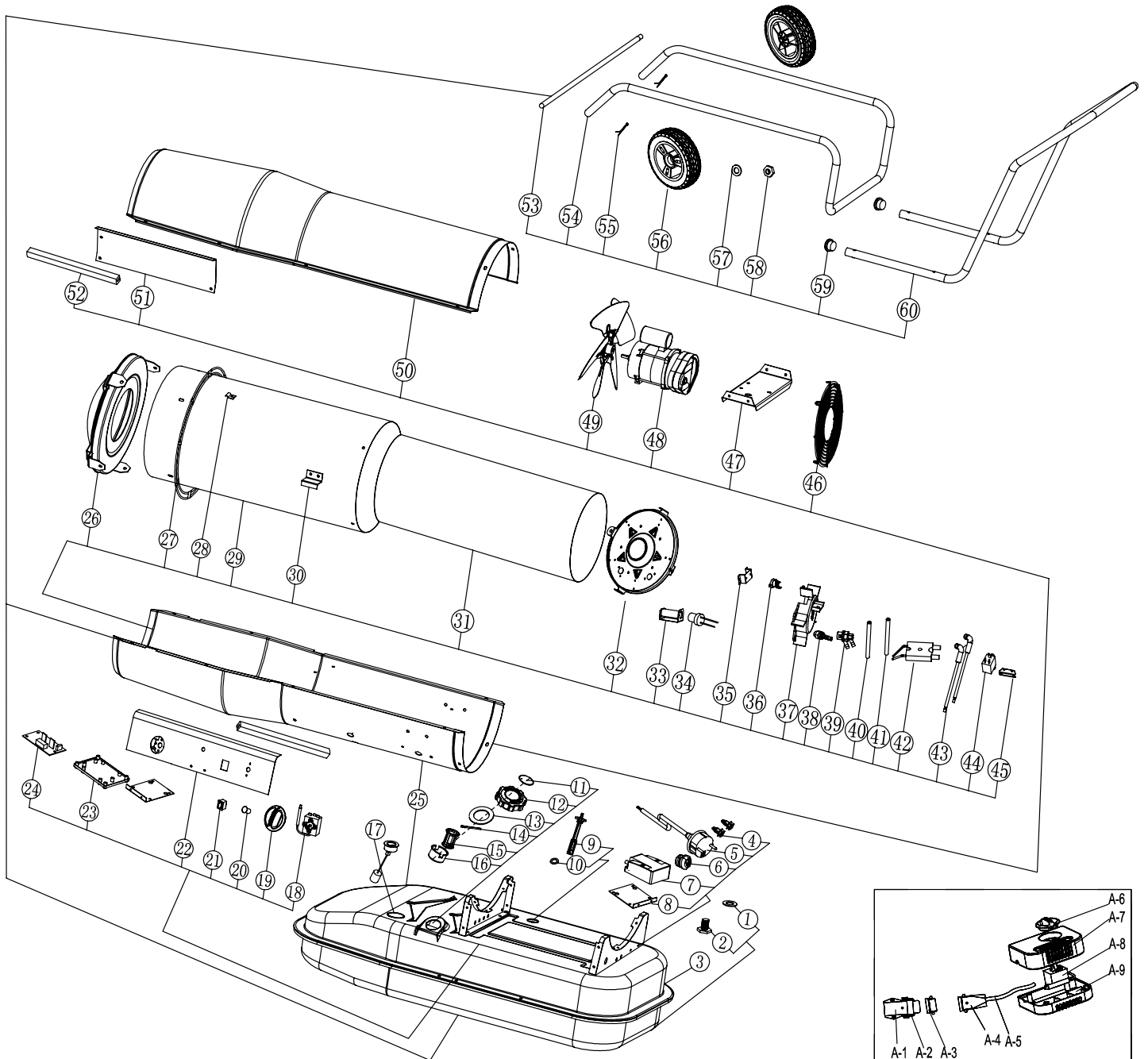

Spare parts list IDE 60 D

NO.	SPARE PART	NO.	SPARE PART	NO.	SPARE PART
1	Oil drain seal ring	24	Power PCB	47	Motor support
2	Oil drain screw	25	Bottom cover	48	Motor assembly
3	Fuel tank	26	Front cover ass'y	49	Fan
4	Support	27	Support ring	50	Top cover
5	Power cord	28	Clamp	51	Side plate
6	Cable fastener	29	Combustion chamber shield	52	Waterproof gasket
7	Ignition transformer	30	Chamber shield bracket	53	Wheel axle
8	Bracket of Ignition transformer	31	Combustion chamber	54	Feet pipe
9	Fuel filter ass'y	32	Burner support plate	55	Cotter pin
10	Sealing ring	33	Photocell assembly bracket	56	Wheel
11	Breath cover	34	Photocell assembly	57	Flat gasket
12	Fuel tank cap	35	Re-set thermostat bracket	58	Screw nut
13	Sealing ring	36	Re-set thermostat	59	Stell pipe plug
14	Tank cap shaft	37	Flame palte	60	Handle
15	Oil inlet filter	38	Nozzle assembly	A-1	Remote control connecter female shell
16	Oil inlet filter holder	39	Nozzle Adapter	A-2	Buckle
17	Oil leveler	40	Gas hose	A-3	Remote control connecter male cover
18	Adjustable thermostat with probe	41	Oil hose	A-4	Remote control connecter male shell
19	Thermostat knob	42	Ignition needle	A-5	Line
20	Light cover	43	High voltage cable	A-6	Thermostat knob
21	On/off switch	44	Solenoid valve	A-7	Probe protection top cover
22	Control panel	45	Solenoid valve bracket	A-8	Adjustable thermostat with probe
23	PCB bracket	46	Air inlet grill	A-9	Probe protection bottom cover

Overview of spare parts IDE 100 D

Note!

The position numbers of the spare parts differ from those describing the positions of the components mentioned in these instructions.

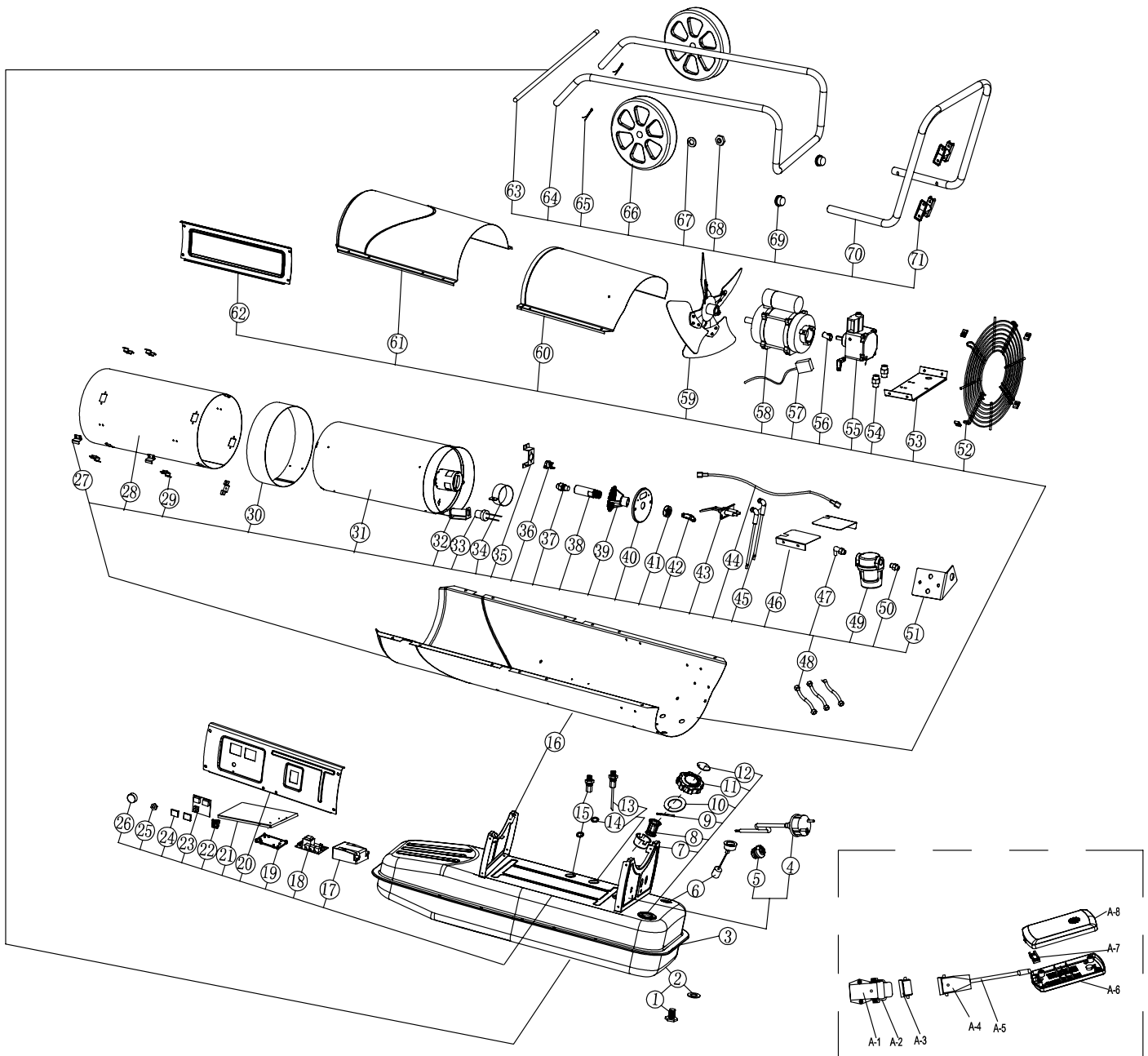

Spare parts list IDE 100 D

NO.	SPARE PART	NO.	SPARE PART	NO.	SPARE PART
1	Oil drain screw	28	Heat insulation	55	Gear pump
2	Oil drain seal ring	29	Chamber bracket	56	Pump coupling
3	Fuel tank	30	Casing support ring	57	Valve cord
4	Power cord	31	Combustion chamber	58	Motor
5	Cable fastener	32	Photocell ass'y	59	Fan
6	Oil leveler	33	Photocell ass'y bracket	60	Top back cover
7	Oil inlet filter holder	34	Air adjustment ring	61	Top front cover
8	Oil inlet filter	35	Thermostat bracket	62	Side plate
9	Tank cap shaft	36	Re-set thermostat	63	Wheel axle
10	Sealing ring	37	Nozzle ass'y	64	Feet pipe
11	Fuel tank cap	38	Nozzle Adapter	65	Cotter pin
12	Breath cover	39	Swirl disc	66	Wheel
13	Oil suction pipe	40	Nozzle base plate	67	Flat gasket
14	Sealing ring	41	Screw nut	68	Screw nut
15	Oil pipe union	42	Elbow connection	69	Steel pipe plug
16	Bottom casing	43	Ignition needle	70	Handle
17	Ignition transformer	44	Oil tube assembly	71	Cable holder
18	Power PCB1	45	High voltage cable	A-1	Socket
19	PCB Support	46	Air balance plate	A-2	Buckle
20	Control panel	47	Filter elbow connection	A-3	Socket cap
21	Support bracket	48	Oil pipe	A-4	Plug
22	On/off switch	49	Filter	A-5	Remote control cable
23	Display PCB2	50	Filter straight connection	A-6	Bottom cover
24	Display window	51	Filter support	A-7	Fixing clip
25	Fixing nut	52	Air inlet grill	A-8	Top cover
26	Thermostat knob	53	Motor support		
27	Hook	54	Fuel pipe joint		

Disposal

Always dispose of packing materials in an environmentally friendly manner and in accordance with the applicable local disposal regulations.



The icon with the crossed-out waste bin on waste electrical or electronic equipment is taken from Directive 2012/19/EU. It states that this device must not be disposed of with the household waste at the end of its life. You will find collection points for free return of waste electrical and electronic equipment in your vicinity. The addresses can be obtained from your municipality or local administration. You can also find out about other return options that apply for many EU countries on the website <https://hub.trotec.com/?id=45090>. Otherwise, please contact an official recycling centre for electronic and electrical equipment authorised for your country.

The separate collection of waste electrical and electronic equipment aims to enable the re-use, recycling and other forms of recovery of waste equipment as well as to prevent negative effects for the environment and human health caused by the disposal of hazardous substances potentially contained in the equipment.

Fuel oil

The fuel oil must be drained from the device and collected.

Fuels are to be disposed of according to the national regulations.

Only for United Kingdom

According to Waste Electrical and Electronic Equipment Regulations 2013 (SI 2013/3113) (as amended) devices that are no longer usable must be collected separately and disposed of in an environmentally friendly manner.

Declaration of conformity

Declaration of conformity in accordance with the EC Machinery Directive 2006/42/EC, Annex II, Part 1, Section A

We – Trotec GmbH – declare in sole responsibility that the product designated below was developed, constructed and produced in compliance with the requirements of the EC Machinery Directive in the version 2006/42/EC.

Product model / product: IDE 20 D, IDE 30 D,
IDE 50 D, IDE 60 D, IDE 100 D

Product type: oil heater

Year of manufacture as of: 2026

Relevant EU directives:

- 2011/65/EU
- 2012/19/EU
- 2014/30/EU
- 2015/863/EU

Applied harmonised standards:

- EN 60335-1:2012
EN 60335-1:2012/AC:2014
EN 60335-1:2012/A11:2014
EN 60335-1:2012/A13:2017
EN 60335-1:2012/A15:2021
- EN 60335-2-102:2016

Applied national standards and technical specifications:

- EN 60335-1:2012/A16:2023
- EN 62233:2008
- EN IEC 55014-1:2021
- EN IEC 55014-2:2021
- EN IEC 61000-3-2:2019/A1:2021
- EN IEC 61000-3-2:2019/A2:2024
- EN 61000-3-3:2013/A1:2019
- EN 61000-3-3:2013/A2:2021
- EN 13842:2004

Manufacturer and name of the authorised representative of the technical documentation:

Trotec GmbH

Grebbener Straße 7, D-52525 Heinsberg

Phone: +49 2452 962-400

E-mail: info@trotec.de

Place and date of issue:

Heinsberg, 18.05.2026



Joachim Ludwig, Managing Director

Trotec GmbH

Grebener Str. 7
D-52525 Heinsberg

☎ +49 2452 962-400

☎ +49 2452 962-200

✉ info@trotec.com

www.trotec.com