

IDS 20 D / IDS 30 D

EN

ORIGINAL INSTRUCTIONS
OIL HEATER



Table of contents

Notes regarding the instructions 2

Safety 2

Information about the device 5

Transport and storage 7

Assembly and start-up 7

Operation 11

Available accessories 12

Errors and faults 12

Maintenance 13

Technical annex 14

Disposal 15

Declaration of conformity 15

Notes regarding the instructions

Symbols

 **Warning of electrical voltage**
This symbol indicates dangers to the life and health of persons due to electrical voltage.

 **Warning of flammable substances**
This symbol indicates dangers to the life and health of persons due to flammable substances.

 **Warning of hot surface**
This symbol indicates dangers to the life and health of persons due to hot surface.

 **Warning**
This signal word indicates a hazard with an average risk level which, if not avoided, can result in serious injury or death.

 **Caution**
This signal word indicates a hazard with a low risk level which, if not avoided, can result in minor or moderate injury.

Note
This signal word indicates important information (e.g. material damage), but does not indicate hazards.



Info

Information marked with this symbol helps you to carry out your tasks quickly and safely.



Follow the manual

Information marked with this symbol indicates that the instructions must be observed.

You can download the current version of the instructions and the EU declaration of conformity via the following link:



IDS 20 D



<https://hub.trotec.com/?id=42204>

IDS 30 D



<https://hub.trotec.com/?id=42205>

Safety

Read this manual carefully before starting or using the device. Always store the manual in the immediate vicinity of the device or its site of use.



Warning

Read all safety warnings and all instructions.

Failure to follow the warnings and instructions may result in electric shock, fire and/or serious injury.

Save all warnings and instructions for future reference.

This device must not be used by children and persons under 16 years of age.

Children shall not play with the appliance. Cleaning and user maintenance shall not be made by children under 16 years.



Warning

Do not use the device in rooms if persons are present who cannot leave the room independently and who are not under constant supervision.

- Do not use the device in potentially explosive rooms or areas and do not install it there.
- Do not use the device in aggressive atmosphere.
- Only put up the device in an upright, stable position on firm ground.

- Let the device dry out after a wet clean. Do not operate it when wet.
- Do not use the device with wet or damp hands.
- Do not expose the device to directly squirting water.
- Never insert any objects or limbs into the device.
- Do not cover the device during operation.
- Do not remove any safety signs, stickers or labels from the device. Keep all safety signs, stickers and labels in legible condition.
- Attention: In Germany, the Federal Emission Protection Directive applies. Do not operate the device for more than 3 months at the same place. Prior to planning the flue gas system, gather information about the national legislation and contact a responsible specialist.
- Do not sit on the device.
- This appliance is not a toy. Keep away from children and animals. Do not leave the device unattended during operation.
- Check accessories and connection parts for possible damage prior to every use of the device. Do not use any defective devices or device parts.
- Ensure that all electric cables outside of the device are protected from damage (e.g. caused by animals). Never use the device if electric cables or the power connection are damaged!
- The mains connection must correspond to the specifications in the Technical annex.
- Insert the mains plug into a properly fused mains socket.
- Observe the device's power input, cable length and intended use when selecting extensions to the power cable. Completely unroll extension cables. Avoid electrical overload.
- Before carrying out maintenance, care or repair work on the device, remove the mains plug from the mains socket. Hold onto the mains plug while doing so.
- Switch the device off and disconnect the power cable from the mains socket when the device is not in use.
- Do not under any circumstances use the device if you detect damages on the mains plug or power cable. If the power cable is damaged, it must be replaced by the manufacturer, its service agent or similarly qualified persons in order to avoid a hazard. Defective power cables pose a serious health risk!
- When positioning the device, observe the minimum distances from walls and other objects as well as the storage and operating conditions specified in the Technical annex.
- Do not use the device in immediate proximity to curtains, beds or sofas.
- Make sure that the air inlet and outlet are not obstructed.
- Make sure that the suction side is kept free of dirt and loose objects.
- Do not place the device on combustible ground.
- Only transport the device in an upright position.
- Only use original spare parts, for otherwise safe and functional operation cannot be ensured.

Intended use

The device was developed for the purpose of generating hot air and may only be used in roofed over outdoor areas or in well-ventilated interior spaces whilst adhering to the technical data.

The device is suited for heating large rooms such as tents, warehouses, workshops, construction sites, greenhouses or agricultural halls.

It is intended to be used without frequent site changes.

The device may only be used in rooms with sufficient fresh air supply and exhaust discharge.

The device must only be operated with EL (ultra-light) fuel oil, kerosene and diesel, however not with petrol, heavy fuel oil etc.

Foreseeable misuse

- Do not place any objects, e.g. clothing, on the device.
- Do not use this device in the vicinity of fuel, solvents, varnishes or other easily inflammable vapours or in rooms where these substances are stored.
- Do not use the device out of doors.
- The device must not be positioned or operated in areas with a high risk of fires or in potentially explosive atmospheres.
- Do not use the device out of doors, unless under a roof.
- The device must not be operated in rooms with an insufficient combustion air supply.
- Do not make any unauthorised modifications, alterations or structural changes to the device.

Personnel qualifications

People who use this device must:

- be aware of the dangers resulting from heat, fire hazard and insufficient ventilation when working with oil heaters.
- be aware of the dangers that occur when handling fuels such as EL fuel oil or diesel.
- have read and understood the instructions, especially the Safety chapter.

Residual risks



Warning of electrical voltage

Work on the electrical components must only be carried out by an authorised specialist company!



Warning of electrical voltage

Before any work on the device, remove the mains plug from the mains socket!
Do not touch the mains plug with wet or damp hands. Hold onto the mains plug while pulling the power cable out of the mains socket.



Warning of flammable substances

Handling fuels entails a risk of fire.
Take sufficient precautions when handling fuels such as fuel oil, kerosene or diesel.
Do not spill any diesel, kerosene or fuel oil! Do not inhale the vapours nor swallow any fuel! Avoid skin contact!



Warning of hot surface

Parts of the device, especially at the air outlet, become very hot during operation. There is a danger of burning and fire. Do not touch the device during operation!
During operation observe a safety distance of at least 3 m to the device front! Observe the minimum distance from walls or other objects according to the technical data!



Warning of hot surface

Some parts of this product can become very hot and cause burns. Particular attention has to be given where children and vulnerable people are present!



Warning of hot surface

Improper handling entails a risk of burning. Only use the device as intended!



Warning

Improper handling entails a risk of burning and electric shock.
Only use the device as intended!



Warning

Dangers can occur at the device when it is used by untrained people in an unprofessional or improper way!
Observe the personnel qualifications!



Warning

The device is not a toy and does not belong in the hands of children.



Warning

Risk of suffocation!
Do not leave the packaging lying around. Children may use it as a dangerous toy.



Warning

Improper installation entails a risk of fire.
Do not place the device on combustible ground.
Do not place the device on high-pile carpets.



Warning

The device must not be covered, there is an imminent fire hazard!

Behaviour in the event of an emergency

1. In an emergency, disconnect the device from the mains feed-in: Switch the device off and disconnect it from the mains.
2. Remove persons from the danger area.
3. Do not reconnect a defective device to the mains.

Overheating protection

The device is provided with a safety thermostat which is activated by overheating of the device (when exceeding the operating temperature).

Investigate the cause of overheating.

If the safety thermostat does not switch in the event of overheating, the overheating protection will be tripped. In that case the device switches off completely. If so, please contact the customer service to have the overheating protection replaced.

Information about the device

Device description

The indirectly fired oil heater serves the purpose of heating the room air so as to quickly heat large, well-ventilated rooms. The oil heater runs on fuel oil or diesel, it must not be used with petrol, heavy fuel oil etc.

It is an oil heater with indirect combustion to be installed in roofed outdoor areas or in rooms with a sufficient fresh air supply.

The selection option between two operating modes permits both a manual regulation of the oil heater by the user and an automatic control aided by an external thermostat.

Functional principle

The device generates warmth by conveying the sucked-in, cold air past a combustion chamber. Inside the combustion chamber the fuel is burned. The sucked-in air is heated and fed back to the environment via the air outlet.

A part of the sucked-in air is compressed and conducted to the injection. The fuel is fed from the tank to the injection by the negative pressure thus created. An ignition contact at the injection ignites the fuel, which is then burned in a continuous flame.

Device depiction

IDS 20 D

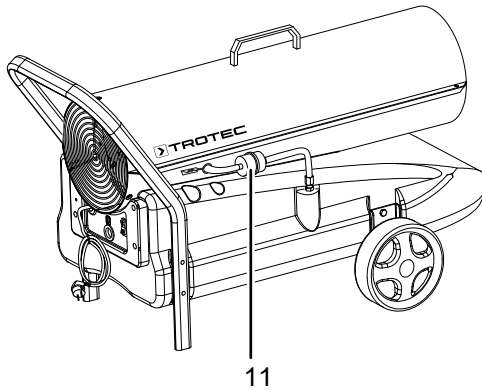
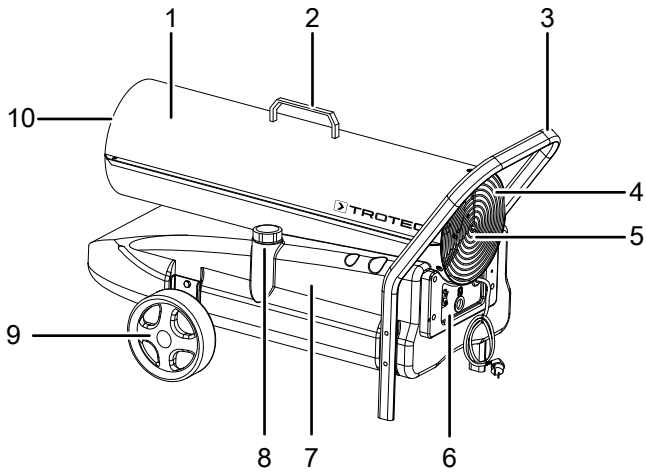

IDS 30 D

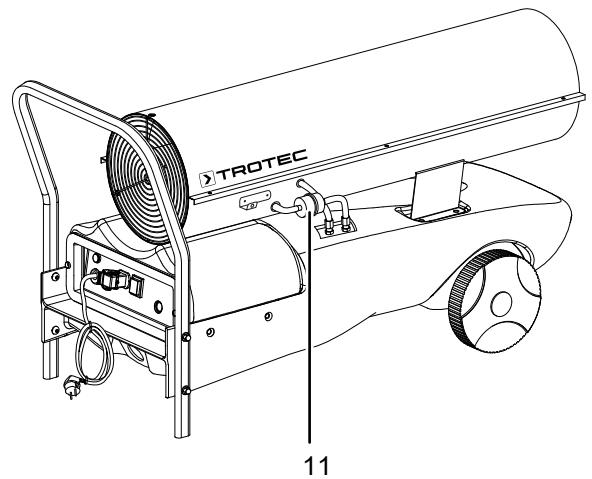
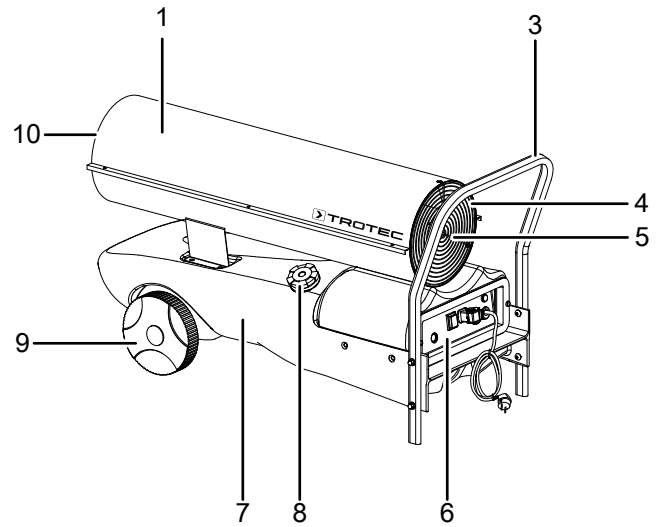

No.	Designation
1	Combustion chamber housing
2	Handle
3	Transport handle
4	Air inlet with protective grid
5	Fan and motor
6	Control panel
7	Tank
8	Fuel tank cap
9	Wheel
10	Air outlet for hot air
11	Fuel pump

Transport and storage

Note

If you store or transport the device improperly, the device may be damaged.

Note the information regarding transport and storage of the device.

Transport

To make the device easier to transport, it is fitted with wheels.

To make the device easier to transport, it is fitted with a carry handle.

To make the device easier to transport, it is fitted with a transport handle and two wheels.

Before transporting the device, observe the following:

- Switch the device off.
- Hold onto the mains plug while pulling the power cable out of the mains socket.
- Do not use the power cable to drag the device.
- Allow the device to cool down sufficiently.

While transporting the device, observe the following:

- Slightly lift the device by the transport handle until the rear support no longer touches the ground.
- Wheel the device to the desired position.

Storage

Before storing the device, proceed as follows:

- Hold onto the mains plug while pulling the power cable out of the mains socket.
- Allow the device to cool down sufficiently.

When the device is not being used, observe the following storage conditions:

- dry and protected from frost and heat
- in an upright position where it is protected from dust and direct sunlight
- with a cover to protect it from invasive dust, if necessary

Assembly and start-up

Scope of delivery

- 1 x Oil heater
- 1 x Transport handle
- 2 x Wheel
- 1 x Installation material
- 1 x Manual

Unpacking the device

1. Open the cardboard box and take the device out.
2. Completely remove the packaging.
3. Fully unwind the power cable. Make sure that the power cable is not damaged and that you do not damage it during unwinding.

Assembly

Upon delivery the device is already partially preassembled. The wheels, axle and transport handle still need to be mounted.

Assembling the wheels

Prior to initial start-up, the wheels and the axle must be mounted to the device. To do so, please proceed as follows:

IDS 20 D

1. Fasten the axle supports (12) at the intended positions at the side of the device.
2. Screw down the axle supports using the supplied screws and washers.

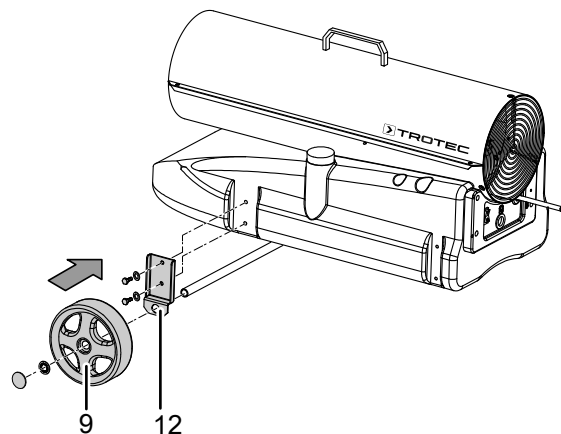

3. Attach both wheels (9) to the axle.
4. Attach the locking rings to the axle.
5. Fasten the wheel caps to the wheels.

IDS 30 D

1. Fit the two wheels on the axle.

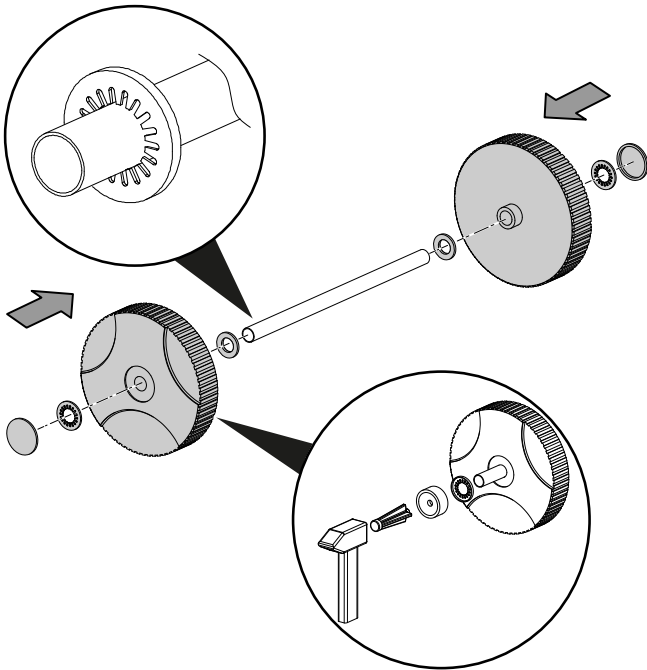

2. Attach the locking rings to the axle.
3. Mount the axle to the bottom of the device.

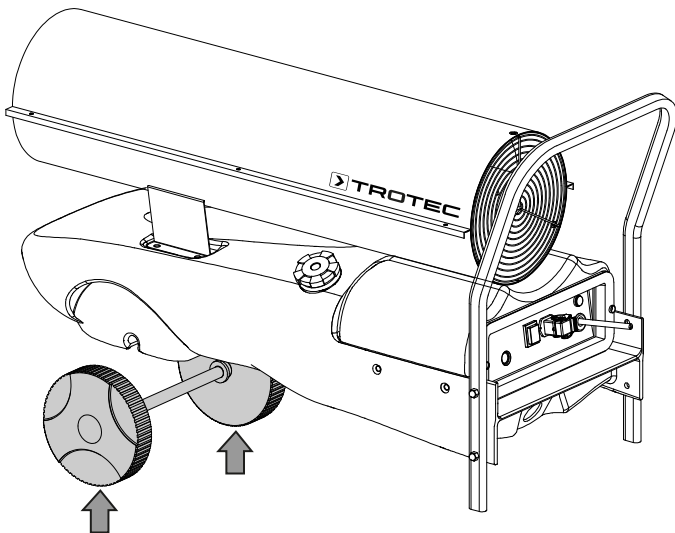

Mounting the transport frame

IDS 20 D

1. Connect the transport frame to the rear of the device.
2. Make sure that the holes for the screws are positioned flush above each other.

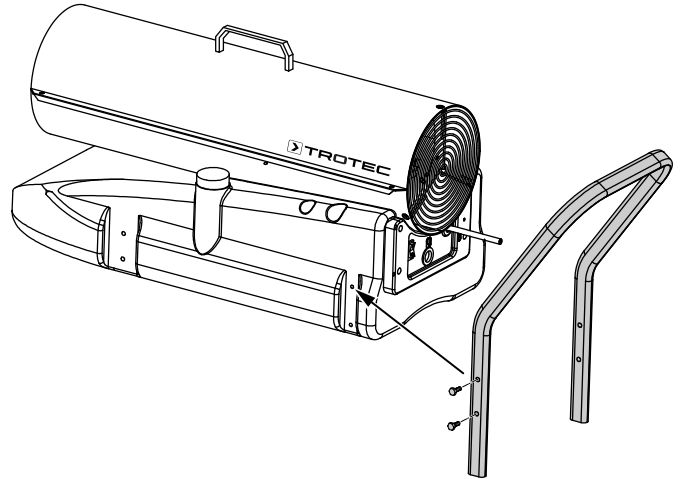

3. Bolt the screws to the device and frame.

IDS 30 D

1. Connect the transport frame to the rear of the device.
2. Make sure that the holes for the screws are positioned flush above each other.

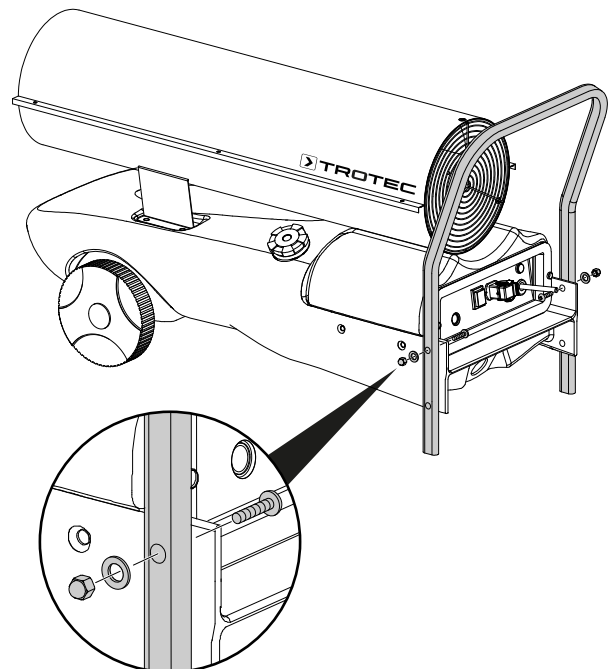

3. Bolt the screws to the device and frame.

Positioning

A number of spatial and technical conditions have to be considered for the selection of the device's installation site. Non-observance may impair the proper functioning of the device or the accessories or can entail risks of personal injury and property damage.

The following is to be observed for positioning:

- Do not operate the device for more than 3 months at the same place. Prior to planning the flue gas system, gather information about the national legislation and contact a responsible specialist.
- The device may only be operated on roofed over surfaces.
- The device is to be set up in a stable position on incombustible ground.
- The device must be set up in close proximity to a chimney, an outer wall or on an open, ventilated surface.
- The device must be connected to a properly secured mains power socket.
- The room where the device is positioned must be sufficiently ventilated.

Ensure a sufficient fresh air supply, especially when there are people or animals in the same room with the device!

- The minimum distance between walls or other objects and the air outlet opening of the device must be at least 3 m (see figure).

The minimum distance between walls or other objects and the air inlet opening of the device must be at least 2 m (see figure).

There must be no walls or large objects near the device.

- The inlet and outlet openings must not be covered.

- There must be a sufficient number of fire extinguishers available.

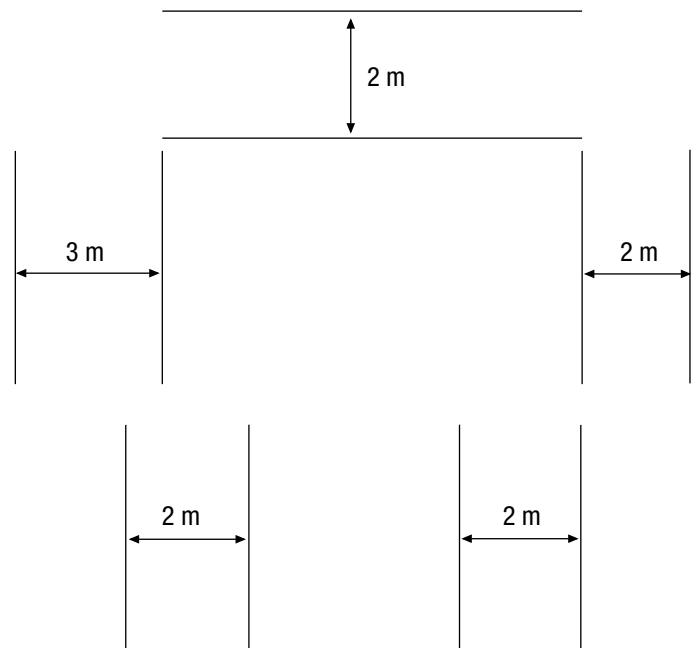

Start-up

- Check the scope of delivery of your device for completeness. If an accessory part is missing, please contact the Trotec customer service or the specialist dealer where you purchased the device.
- Check the device and its connection parts for potential damage.
- Observe the conditions described in the chapter Positioning.
- Fill the tank with EL fuel oil, kerosene or diesel as described in chapter Assembly
- Check the device for its proper condition prior to start-up and at regular intervals during application.
- Check whether the characteristics of the power grid conform to those on the nameplate.
- Each time before you plug the mains plug into the mains socket and switch on the device, make sure that the fan is moving freely.
- Connect the power cable to a properly secured socket. On construction sites, there must be a residual current device (RCD) upstream of the socket in accordance with national regulations (in Germany: VDE 0100/0105).

The device is now ready for operation.

Filling the tank

The fuel tank cap is located at the side of the IDS 20 D / IDS 30 D. The images in the description below show the IDS 30 D by way of example.

- ✓ Before attempting to fill the tank, wait until the device has cooled down completely.
 - ✓ Only use fuel suitable for the device (see technical data).
1. Position the device on firm, level and incombustible ground.
 2. Unscrew the fuel tank cap (7).

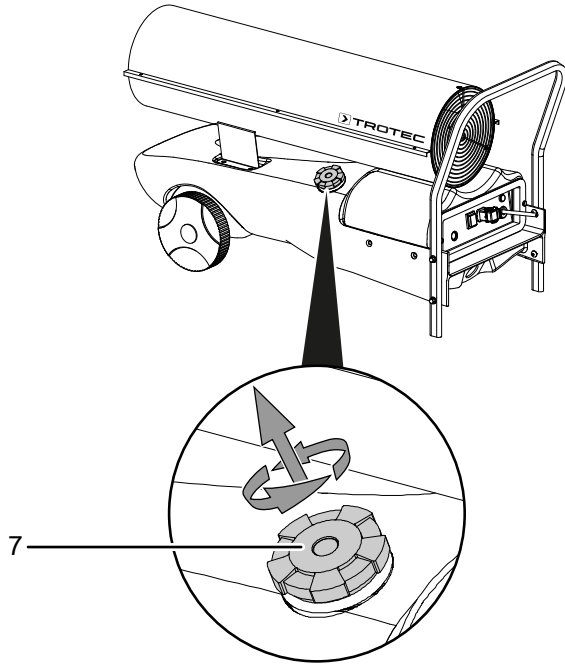

3. Fill the tank.

4. Screw the fuel tank cap (7) back onto the tank. Observe the recesses at the tank opening and the protrusions at the fuel tank cap. They must be aligned when attaching the fuel tank cap. Make sure that the fuel tank cap is firmly attached to avoid leakage.

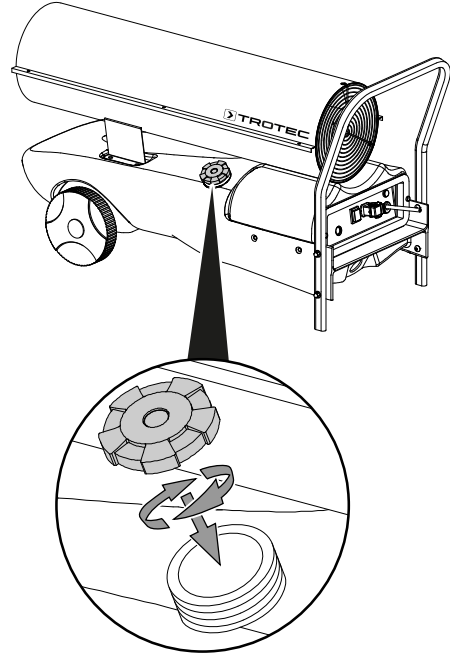

Operation

The device may only be used by accordingly instructed persons.

Operating elements

IDS 20 D

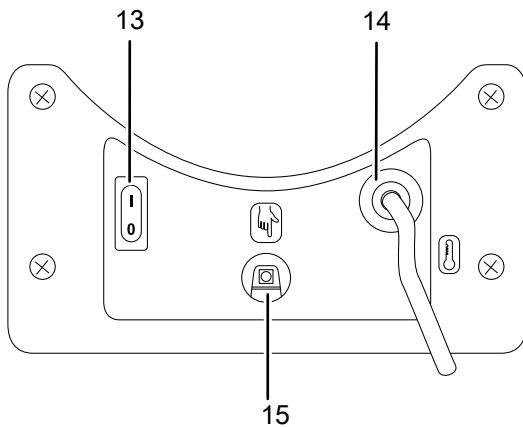

No.	Designation
13	On/off switch
14	Power cable
15	Thermostat socket (optional for IDS 20 D)

IDS 30 D

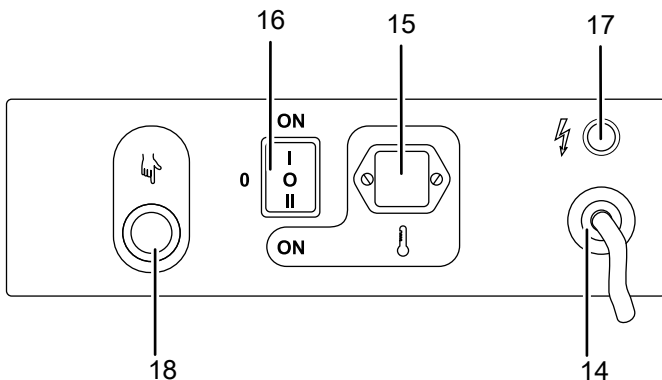

No.	Designation
14	Power supply cable
15	Thermostat socket
16	Selector switch (continuous operation/thermostat operation)
17	Operating light
18	Reset button with indicator light

Switching the device on

IDS 20 D

The IDS 20 D comes with a heating level without thermostat and without integrated thermostat socket. Without a thermostat connected, the IDS 20 D can only be used in continuous operation mode. Optionally, the device can be equipped with a thermostat and a thermostat socket to additionally allow for automatic operation.

Switch-on in continuous operation mode

1. Set the on/off switch (13) to position **I**.
2. The fan starts up and combustion starts after a few seconds.
3. Ensure a successful ignition.

Switch-on in automatic operation mode (optional)

The device can only be operated in automatic operation mode if an optional thermostat is connected to the optional thermostat socket.

- ✓ The device is equipped with an optional thermostat socket.
 - ✓ An optional thermostat is connected to the device.
1. Prepare the device for operation by setting the connected thermostat.
 2. Please note the instructions provided with the thermostat.
 3. Set the on/off switch (13) to position **I**.

IDS 30 D

The IDS 30 D comes with a heating level without thermostat and an integrated thermostat socket. Without a thermostat connected, the IDS 30 D can only be used in continuous operation mode. Optionally, the device can be equipped with a thermostat for the existing thermostat socket to additionally allow for automatic operation.

Switch-on in continuous operation mode

1. Set the selector switch (16) to position **I**.
2. The fan starts up and combustion starts after a few seconds.
3. Ensure a successful ignition.

Switch-on in automatic operation mode (optional)

The device can only be operated in automatic operation mode if an optional thermostat is connected to the integrated thermostat socket.

- ✓ An optional thermostat is connected to the device.
1. Prepare the device for operation by setting the connected thermostat.
 2. Please note the instructions provided with the thermostat.
 3. Set the selector switch (16) to position **II**.

Shutdown



Warning of electrical voltage

Do not touch the mains plug with wet or damp hands.

Note

Damage to the device due to overheating!
 Never switch off the device by pulling the mains plug. This may lead to overheating!
 Switch off the device properly. Only remove the mains plug from the device once the fan motor has stopped completely.

Switch-off in continuous operation mode

1. Switch off the device by setting the selector switch (16) or on/off switch (13) to position **0**.
 ⇒ The selector switch (16) or on/off switch (13) is no longer illuminated.
2. Wait until the fan motor has come to a complete standstill.
3. Secure the device against inadvertent switch-on by pulling the mains plug.
4. Allow the device to cool down completely.

Available accessories

Accessories	Article number
Thermostat with 10 m cable (IDS 30 D only)	6.100.007.016
Tank liquid level indication	6.100.006.160
Filler neck oil filter	6.100.006.161



Warning

Only use accessories and additional equipment specified in the instructions. Using insertion tools or accessories other than those specified in the instructions may cause a risk of injury.

Errors and faults



Warning of electrical voltage

Tasks which require the device to be opened must only be carried out by authorised specialist companies or by Trotec.



Warning

Risk of injury due to improper repair!
 Never try to make any modifications or repairs on the device.
 Unauthorised modifications can lead to serious injuries or death.
 Have a certified specialist workshop perform the repair work.

The device has been checked for proper functioning several times during production. If malfunctions occur nonetheless, check the device according to the following list.

The device does not start:

- Check the power connection.
- Check the power cable and mains plug for damages.
- Check the on-site fusing.

Smoke and/or sparks are emitted during first use:

- This is not a fault. These phenomena disappear after a brief runtime.

Noise emission during ignition or cooling:

- This is not a fault. The metal parts of the device expand when heated and generate noise.

Sparks and/or flame may be issued from the device during ignition:

- This is not a fault. Air might have accumulated in the lines. Keep a safety distance to the device!

The flame in the combustion chamber does not ignite:

- Check the filling level of the tank. Refill fuel if the tank is empty (see chapter Maintenance).
- Check the fuel filter in the fuel pump for dirt. If it is dirty, please contact the customer service.
- Check the fuel for contaminations, e.g. dirt or water. If required, drain the fuel completely and fill in new fuel (see chapter Maintenance).
- Safety shutdown: if the flame dies during operation, the electronics and the oil pump will be switched off. Investigate the cause on the basis of the following criteria:
 - **For qualified personnel only!**
 Check the ignition: The distance between the two ignition electrodes should be 4 to 5 mm.

The flame goes out during combustion:

- Make sure the air supply is unobstructed. If required, clean the air intake opening.
- Check the filling level of the tank. Refill with fuel if the tank is empty (see chapter Operation).
- Check the fuel filter in the fuel pump for dirt. If it is dirty, please contact the customer service.
- Check the fuel for contaminations and replace it if required.
- Power failure: In the event of a power failure the ignition is extinguished, the device switches off immediately. After a power failure the device will not restart automatically, it has to be started via the on/off switch.

There is a fuel leak:

- Check whether too much fuel was filled in. Drain the fuel if necessary, see chapter Draining the tank.
- Check the drain screw for tight fit and retighten it if necessary.
- Check the sealing at the drain screw and replace it if damaged.
- Check the fuel pump for leaks. If there are doubts about the proper condition of the fuel pump, please contact the customer service.

The device emits smoke or dust:

- Check the mains voltage.
- Check the fuel for contaminations and replace it if required.
- Check the tank for contaminations and drain it if required (see chapter Maintenance). Refill with clean fuel.

The flame emerges from the air outlet:

- Check the mains voltage.
- Check the fuel for contaminations and replace it if required.
- Check the tank for contaminations and drain it if required (see chapter Maintenance). Refill with clean fuel.

Note

Wait for at least 3 minutes after maintenance and repair work. Only then switch the device back on.

The device still does not operate correctly after these checks:

Please contact the customer service. If necessary, bring the device to an authorised specialist electrical company or to Trotec for repair.

Maintenance

Activities required before starting maintenance



Warning of electrical voltage

Do not touch the mains plug with wet or damp hands.

- Switch the device off.
- Hold onto the mains plug while pulling the power cable out of the mains socket.
- Allow the device to cool down completely.



Warning of electrical voltage

Tasks which require the device to be opened must only be carried out by authorised specialist companies or by Trotec.

Cleaning the housing

Clean the housing with a soft, damp and lint-free cloth. Make sure that no moisture enters the housing. Protect electrical components from moisture. Do not use any aggressive cleaning agents such as cleaning sprays, solvents, alcohol-based or abrasive cleaners to dampen the cloth.

Wipe the housing dry after cleaning.

Draining the tank

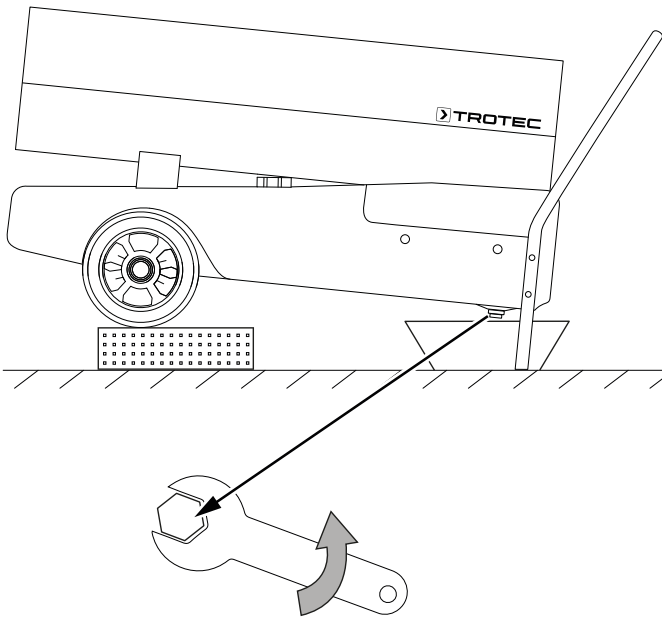

1. Provide for a suitable collection container.
2. Move the device to an elevated position.
3. As indicated in the figure use a wrench to open the screw at the bottom of the tank.
4. Drain the fuel into the collection container.
5. When no more fuel is discharged, seal the drain hole again.
 - ⇒ Ensure the tight fit of the screw and, if required, replace the seal, for otherwise fuel might leak out uncontrollably.
6. Dispose of the fuel according to national regulations.

Technical annex

Technical data

Parameter	Value	
Model	IDS 20 D	IDS 30 D
Combustion	direct	direct
Air flow rate	350 m ³ /h	605 m ³ /h
Fan	axial fan	axial fan
Nominal heat output	20 kW	38.4 kW
Ventilation / air changes per hour	at least 2 ACH	at least 2 ACH
Temperature increase ΔT	100 °C	75 °C
Max. fuel consumption	2.04 l/h	3.66 l/h
Tank capacity	17 l	42 l
Input voltage	230 V / 50 Hz	230 V / 50 Hz
Current consumption	1 A	1.25 A
Overheating protection	yes	yes
Connection for external thermostat	optional	yes
Sound pressure level (distance 1 m)	67 dB(A)	69 dB(A)
Weight (with empty tank)	20 kg	20 kg
Dimensions (length x width x height)	720 x 300 x 450 mm	1050 x 400 x 520 mm
Minimum distance to walls or other objects		
top	2 m	2 m
rear	2 m	2 m
sides	2 m	2 m
front	3 m	3 m
Permitted fuel	EL fuel oil, diesel or kerosene	EL fuel oil, diesel or kerosene

Disposal



The icon with the crossed-out waste bin on waste electrical or electronic equipment stipulates that this equipment must not be disposed of with the household waste at the end of its life. You will find collection points for free return of waste electrical and electronic equipment in your vicinity. The addresses can be obtained from your municipality or local administration. You can also find out about other return options that apply for many EU countries on the website <https://hub.trotec.com/?id=45090>. Otherwise, please contact an official recycling centre for electronic and electrical equipment authorised for your country.

The separate collection of waste electrical and electronic equipment aims to enable the re-use, recycling and other forms of recovery of waste equipment as well as to prevent negative effects for the environment and human health caused by the disposal of hazardous substances potentially contained in the equipment.

Fuel oil

The fuel oil must be drained from the device and collected. Fuels are to be disposed of according to the national regulations.

Declaration of conformity

Declaration of conformity in accordance with the EC Machinery Directive 2006/42/EC, Annex II, Part 1, Section A

We – Trotec GmbH – declare in sole responsibility that the product designated below was developed, constructed and produced in compliance with the requirements of the EC Machinery Directive in the version 2006/42/EC.

Product model / Product: IDS 20 D
IDS 30 D

Product type: oil heater

Year of manufacture as of: 2021

Relevant EU directives:

- 2014/30/EU: 29/03/2014

Applied harmonised standards:

- None

Applied national standards and technical specifications:

- None

Manufacturer and name of the authorised representative of the technical documentation:

Trotec GmbH
Grebbeener Straße 7, D-52525 Heinsberg
Phone: +49 2452 962-400
E-mail: info@trotec.de

Place and date of issue:
Heinsberg, 16.06.2021



Detlef von der Lieck, Managing Director

Trotec GmbH

Grebener Str. 7
D-52525 Heinsberg

☎ +49 2452 962-400

☎ +49 2452 962-200

✉ info@trotec.com

www.trotec.com