

EN

INSTRUCTIONS
VIDEOSCOPE



Table of contents

Information on the use of these instructions 2

Safety 2

Information about the device 4

Transport and storage 6

Operation 6

Errors and faults 8

Maintenance and repair 9

Disposal 9

Information on the use of these instructions

Symbols

 **Warning of electrical voltage**
This symbol indicates dangers to the life and health of persons due to electrical voltage.

 **Warning**
This signal word indicates a hazard with an average risk level which, if not avoided, can result in serious injury or death.

 **Caution**
This signal word indicates a hazard with a low risk level which, if not avoided, can result in minor or moderate injury.

Notice
This signal word indicates important information (e.g. material damage), but does not indicate hazards.

 **Info**
Information marked with this symbol helps you to carry out your tasks quickly and safely.

 **Follow the manual**
Information marked with this symbol indicates that the instructions must be observed.

You can download the current version of the instructions and the EU declaration of conformity via the following link:



B022



<https://hub.trotec.com/?id=43579>

Safety

Read this manual carefully before starting or using the device. Always store the manual in the immediate vicinity of the device or its site of use.



Warning

Read all safety warnings and all instructions. Failure to follow the warnings and instructions may result in electric shock, fire and/or serious injury. **Save all warnings and instructions for future reference.**

- Do not use the device in potentially explosive rooms or areas and do not install it there.
- Do not use the device in aggressive atmosphere.
- Do not use the device in atmospheres containing oil, sulphur, chlorine or salt.
- Protect the device from permanent direct sunlight.
- Only use the device in de-energized facilities and objects. For reasons of safety, de-energize all plant components and objects prior to every inspection.
- Before using the measuring probes and camera heads, de-energize any circuits located in walls.
- Before using the measuring probes and camera heads in metal pipes inside a wall, have an authorised specialist company carry out a check to ensure that the metal pipes are not electrically charged.
- For reasons of safety, do not use the measuring probes and camera heads for inspections in moving parts.
- Do not open the device.
- Do not remove any safety signs, stickers or labels from the device. Keep all safety signs, stickers and labels in legible condition.
- Use batteries of type LR06 (AA).
- Never charge batteries that cannot be recharged.
- Different types of batteries and new and used batteries must not be used together.
- Insert the batteries into the battery compartment according to the correct polarity.

- Remove discharged batteries. Batteries contain materials hazardous to the environment. Dispose of the batteries according to the national regulations.
- Remove the batteries from the device if you will not be using the device for a longer period of time.
- Never short-circuit the supply terminal in the battery compartment!
- Do not swallow batteries! If a battery is swallowed, it can cause severe internal burns within 2 hours! These burns can lead to death!
- If you think batteries might have been swallowed or otherwise entered the body, seek medical attention immediately!
- Keep new and used batteries and an open battery compartment away from children.
- Observe the storage and operating conditions (see Technical data).

Intended use

Only use the device for the visualization of objects.

To use the device for its intended use, only use accessories and spare parts which have been approved by Trotec.

Any use other than the intended use is regarded as misuse.

Reasonably foreseeable misuse

Do not use the device:

- in potentially explosive atmospheres
- in live environments
- in unsuitable liquids, e.g. acids and alkalis
- on people or animals

Do not use the control unit with display underwater.

Any unauthorised modifications, alterations or structural changes to the device are forbidden.

Personnel qualification

People who use this device must:

- take measures to protect themselves from direct contact with live parts.
- have read and understood the instructions, especially the Safety chapter.

Residual risks



Warning of electrical voltage

Electric shock due to contact with live parts! Do not touch any live parts. Secure neighbouring live parts by covering them or by switching them off.



Warning of electrical voltage

There is a risk of a short-circuit due to liquids penetrating the housing!

Do not immerse the device and the accessories in water. Make sure that no water or other liquids can enter the housing.



Warning of electrical voltage

Work on the electrical components must only be carried out by an authorised specialist company!



Warning

Magnetic field!

The accessories magnet can affect pacemakers and implanted defibrillators!

Always keep a minimum distance of 20 cm between the device and pacemakers or implanted defibrillators. Persons with pacemakers or implanted defibrillators must not carry the device in their breast pocket.



Warning

Risk of damages or data loss due to magnetic field!

Do not store, carry or use the accessories magnet in the vicinity of data storage media or electronic devices such as hard drives, television units, gas meters or credit cards!

There is a risk of data loss or damages. If possible, keep the highest safety distance possible (at least 1 m).



Warning

Risk of suffocation!

Do not leave the packaging lying around. Children may use it as a dangerous toy.



Warning

The device is not a toy and does not belong in the hands of children.



Warning

Dangers can occur at the device when it is used by untrained people in an unprofessional or improper way! Observe the personnel qualifications!



Caution

Keep a sufficient distance from heat sources.

Notice

To prevent damages to the device, do not expose it to extreme temperatures, extreme humidity or moisture.

Notice

Do not use abrasive cleaners or solvents to clean the device.

Information about the device

Device description

The videoscope B022 serves for inspecting concealed machine components and poorly accessible or inaccessible hollows.

The camera is connected to the device via a flexible gooseneck probe.

The probe is water-proof and can be immersed in water along with the camera head, e.g. to check whether there are any objects underneath the surface or for leak detection in water-carrying systems.

The device is equipped with a 3 inch LC display. If it is used along with a microSD card (not included in the scope of delivery), pictures and videos can be taken.





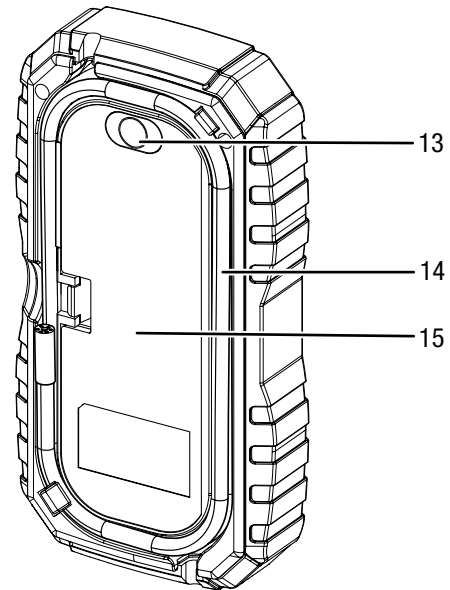
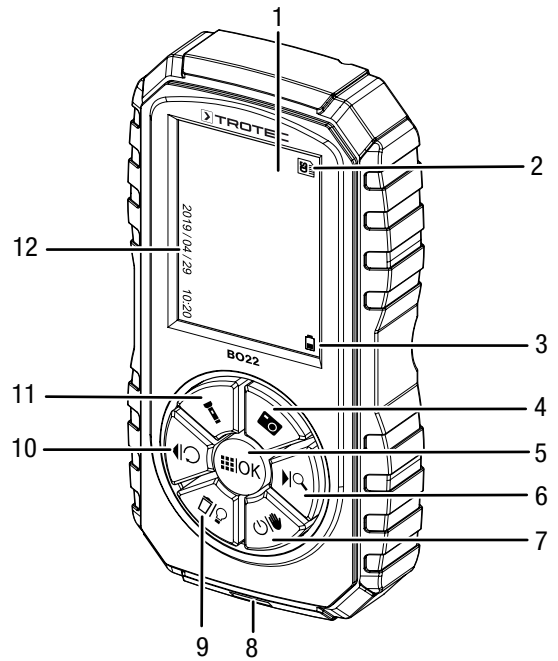

The device is further equipped with a freeze-frame function, with additional lighting and offers the possibility to rotate the image by 180° (flip function).

The tip of the gooseneck probe can be replaced with three further attachments:

- 45° mirror attachment
- hook attachment
- magnet attachment

Device depiction



No.	Element	Function
1	Display	camera image or menu indication
2	MicroSD card indication	indicates whether a microSD card is inserted
3	Battery status indication	flashes red if batteries need to be replaced
4	 button	starts recording pictures or videos
5	 button	runs menu function runs indicated submenu confirms input value
6	 button	up button for the menu zoom function
7	 button	POWER button freeze image
8	MicroSD card recording	insert MicroSD card up to 32 GB
9	 button	deletes data activates camera light (4 levels)
10	 button	down button for the menu 180° image rotation (flip function)
11	 button	activates rear light
12	Date and time indication	settings are made via menu function
13	Rear light	additional object lighting
14	Gooseneck probe	with camera head and lamp, extendable by 95 cm
15	Battery compartment	4 batteries, LR06 AA 1.5 V

Technical data

Parameter	Value
Model	B022
Weight (incl. batteries)	approx. 385 g
Dimensions (length x width x height)	162 mm x 85 mm x 35 mm
Display	3.0 inch digital LC colour display
Memory	on microSD card (up to 32 GB, min. 6 MB/s, not included in the scope of delivery)
Resolution	640 x 480 pixels
Video format	AVI
Video resolution	1280 x 720 pixels
Photo format	JPG
Camera diameter	5.5 mm
Length of the gooseneck probe	95 cm
Depth of field	approx. 1 cm to 30 cm
Field of vision	65°
Zoom	1.0/1.5/2.0-fold zoom
Operating temperature	-10 °C to 60 °C
Storage temperature	-10 °C to 60 °C
Type of protection (gooseneck probe and camera head)	IP67
Power supply	4 batteries, LR06 AA 1.5 V

Scope of delivery

- 1 x Device B022
- 1 x Accessory kit with 45° mirror, hook and magnet attachment
- 1 x Quick guide

Transport and storage

Notice

If you store or transport the device improperly, the device may be damaged.
 Note the information regarding transport and storage of the device.

Transport

For transporting the device, use the bag included in the scope of delivery in order to protect the device from external influences.

Storage

When the device is not being used, observe the following storage conditions:

- dry and protected from frost and heat
- protected from dust and direct sunlight
- protected from dust ingress in the supplied bag
- at the temperature specified in the technical data
- Batteries are removed from the device

Operation

Inserting the batteries

Notice

Make sure that the surface of the device is dry and the device is switched off.

1. Remove the cover of the battery compartment (15).
2. Insert the batteries into the device with correct polarity.

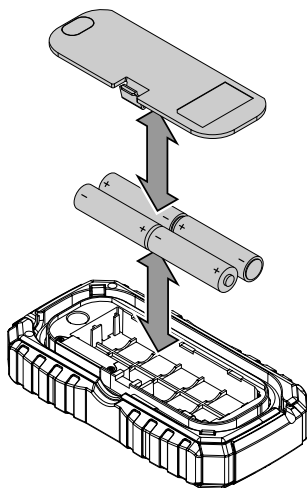

3. Put the cover back onto the battery compartment.

Switching the device on and off

1. Press and hold the (7) for approx. 2 seconds to switch the device on.
 - ⇒ The display (1) switches on.
 - ⇒ The device is ready for operation.
2. Press and hold the (7) again for approx. 2 seconds to switch the device off.

Inserting the microSD card

To take pictures or record videos, you have to insert a microSD card (not included in the scope of delivery) into the device.



Info

Do not push the microSD card forcefully into the retainer (8). Otherwise the card could be damaged. Make sure that the card is correctly aligned.

1. Carefully insert the card into the microSD card slot (8).

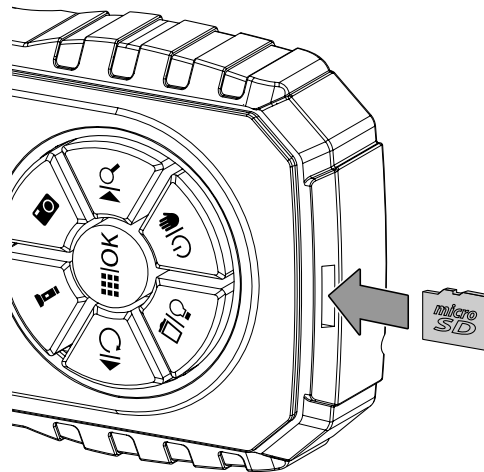

Settings and video menu

The device has an integrated menu where you can adjust settings and take and view pictures and videos. After pressing the (5) button, the main menu will open including the following subitems:

Subitem	Function
Back	- closes the menu
Video mode	- opens the video mode - press the button to start recording
Photo mode	- opens the photo mode - press the button to take a picture
Playback	- opens the playback menu - plays or deletes previously taken photos or videos
Setup	- opens the settings menu - for setting date, time and language - for formatting the microSD card

By pressing the (6) or (10) button, you can browse the menus and adjust the indicated values.

By pressing the (5) button, you can access the displayed submenu, confirm a setting or change the language in the language settings menu.

Aligning / moving the camera



Info

To provide protection, the gooseneck probe is integrated into the device and should be appropriately placed into the device if the camera is not in use.

1. Take out the gooseneck probe (14) to the desired length by unwinding it from the housing. Note that the stability of the gooseneck decreases the more you unwind the probe from the housing.

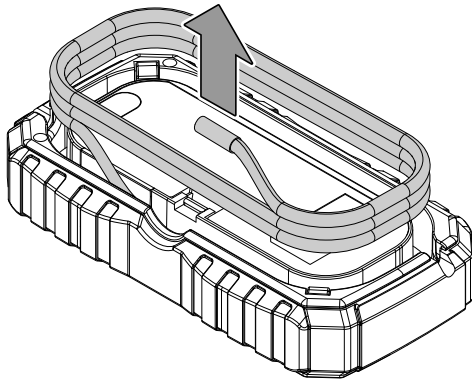

2. Move the camera on the tip of the gooseneck into the desired position.



Info

For underwater photos the gooseneck probe can be immersed. Make sure that the device itself does not make contact with water, otherwise it might be damaged.

3. If necessary, press the ◀|◊ (10) button to turn the camera image by 180°.
4. Press the ◀|◊ (10) button again to turn the camera image back by 180°.

Setting the camera light

The device is equipped with a camera light that offers 4 brightness levels.

1. Press the ◻|◊ (9) button up to four times to set the desired brightness level.
2. Pressing the ◻|◊ (9) button for the fifth time will switch off the camera light.

Taking photos/videos

With inserted microSD card (not included in the scope of delivery) you can take photos or videos with the camera.

1. Briefly press the 📷 button (4) to take a photo with the camera.
2. Press and hold the 📷 button (4) for approx. 2 seconds to access the video mode.
 - ⇒ The symbol of the photo icon on the top left of the display changes to the symbol of a camera icon.
3. In the video mode, press the 📷 button (4) to start recording the video.
 - ⇒ The video recording is started.
 - ⇒ The camera icon in the display flashes and the video runtime is displayed.
4. Press the 📷 button (4) again to stop recording.
 - ⇒ The video recording is stopped.
 - ⇒ The camera icon stops flashing and the runtime display disappears.

Freezing the image

By pressing the 📷 button (7) you can freeze the image to obtain a better view on it.

By pressing the 📷 button (7) again, the display (1) switches back to the live image of the camera.

Setting the zoom factor

By pressing the ▶|◻ button (6) you can switch between three different zoom levels:

- 1.0-fold zoom
- 1.5-fold zoom
- 2.0-fold zoom

The zoom level is indicated on the display (1).

Using the rear light

The device is equipped with an additional rear light (13) to be able to illuminate objects in a better way or to be used as a torch.

1. Press the 🔦 button (11) to switch on the rear light (13).
2. Re-press the 🔦 button (11) to switch off the rear light (13) again.

Using accessories

The scope of delivery includes three additional camera attachments with the following functions:

attachment	Function
45° attachment	allows you to have an around-the-corner view with the camera
hook attachment	allows you to remove objects with the hook, e.g. a ring that fell into the drain
magnet attachment	allows you to remove metals containing iron, nickel or cobalt, e.g. screws or nuts in places that are difficult to access

1. Unscrew the thread protection from the camera.
2. Screw the required attachment on the camera.

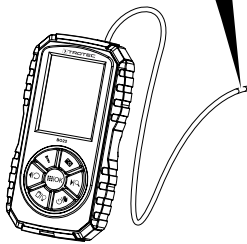
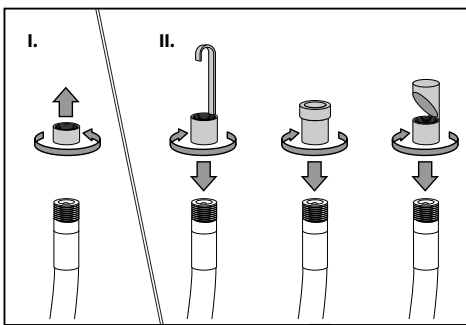

Info

After usage, always screw the thread protection back on the camera head. Otherwise, the thread could be damaged and it might not be possible to use the accessory attachments any longer.

Errors and faults

Fault	Cause	Solution
The device does not switch on.	No batteries are inserted.	Make sure that batteries are inserted.
	The batteries are not properly inserted.	Make sure that the batteries are inserted with correct polarity.
	The batteries are empty.	Make sure that the batteries are new or charged sufficiently.
The device did not record pictures/videos.	No microSD card inserted.	Insert a microSD card.
	The microSD card is full.	Delete files no longer needed to free up storage space.
	The device switched off during recording.	Terminate the recording before the batteries have run empty. Insert new batteries.
MicroSD card cannot be read.	Problem with microSD card.	Make sure that the microSD card is not damaged and the storage space does not exceed 32 GB.
	The system has crashed.	Switch the device off and back on.
The camera image is too bright or too dark.	The camera light is set too bright or too dark.	Set the camera light correctly (see Chapter Operation).
	The rear light influences the image.	Switch the rear light on and off as needed.
The camera light does not work, no image being displayed.	The batteries are not sufficiently charged.	Insert new batteries.
	Communication error between camera and device.	Check the connection between gooseneck probe and device.
	The camera is damaged.	Please contact the customer service.
The recorded video stutters.	The microSD card transfer speed is lower than 6 MB/s.	Use another microSD card with a transfer speed of at least 6 MB/s.

Maintenance and repair

Battery change

Change the batteries if the *Battery status* indication (3) flashes in red or if the device can no longer be switched on. See section Inserting the batteries in chapter Operation.

Cleaning

Clean the device with a soft, damp and lint-free cloth. Make sure that no moisture enters the housing. Do not use any sprays, solvents, alcohol-based cleaning agents or abrasive cleaners, but only clean water to moisten the cloth.

Repair

Do not modify the device or install any spare parts. For repairs or device testing, contact the manufacturer.

Disposal

Always dispose of packing materials in an environmentally friendly manner and in accordance with the applicable local disposal regulations.



The icon with the crossed-out waste bin on waste electrical or electronic equipment is taken from Directive 2012/19/EU. It states that this device must not be disposed of with the household waste at the end of its life. You will find collection points for free return of waste electrical and electronic equipment in your vicinity. The addresses can be obtained from your municipality or local administration. You can also find out about other return options that apply for many EU countries on the website <https://hub.trotec.com/?id=45090>. Otherwise, please contact an official recycling centre for electronic and electrical equipment authorised for your country.

The separate collection of waste electrical and electronic equipment aims to enable the re-use, recycling and other forms of recovery of waste equipment as well as to prevent negative effects for the environment and human health caused by the disposal of hazardous substances potentially contained in the equipment.



In the European Union, batteries and accumulators must not be treated as domestic waste, but must be disposed of professionally in accordance with Directive 2006/66/EC of the European Parliament and of the Council of 6 September 2006 on batteries and accumulators. Please dispose of batteries and accumulators according to the relevant legal requirements.

Only for United Kingdom

According to Waste Electrical and Electronic Equipment Regulations 2013 (SI 2013/3113) (as amended) and the Waste Batteries and Accumulators Regulations 2009 (SI 2009/890) (as amended), devices that are no longer usable must be collected separately and disposed of in an environmentally friendly manner.

Trotec GmbH

Grebener Str. 7
D-52525 Heinsberg

☎ +49 2452 962-400

☎ +49 2452 962-200

✉ info@trotec.com

www.trotec.com