

# TDP 5500 E / TDP 7500 E / TDP 7501 E

**EN**

**ORIGINAL INSTRUCTIONS**  
DEEP WELL PUMP



**Table of contents**

**Information on the use of these instructions** ..... 2

**Safety** ..... 2

**Information about the device**..... 6

**Transport and storage**..... 6

**Assembly and installation**..... 7

**Operation** ..... 9

**Available accessories**..... 10

**Errors and faults**..... 10

**Maintenance** ..... 11

**Technical annex**..... 12

**Disposal** ..... 24

**Declaration of conformity** ..... 24

**Information on the use of these instructions**

**Symbols**

 **Warning of electrical voltage**  
 This symbol indicates dangers to the life and health of persons due to electrical voltage.

 **Warning**  
 This signal word indicates a hazard with an average risk level which, if not avoided, can result in serious injury or death.

 **Caution**  
 This signal word indicates a hazard with a low risk level which, if not avoided, can result in minor or moderate injury.

 **Warning**  
 Warnings marked with this symbol indicate a risk of falling.

**Notice**  
 This signal word indicates important information (e.g. material damage), but does not indicate hazards.

 **Info**  
 Information marked with this symbol helps you to carry out your tasks quickly and safely.



**Follow the manual**

Information marked with this symbol indicates that the instructions must be observed.

You can download the current version of these instructions via the following link:

TDP 5500 E



<https://hub.trotec.com/?id=42888>



TDP 7500 E



<https://hub.trotec.com/?id=42889>

TDP 7501 E



<https://hub.trotec.com/?id=47547>

**Safety**

**Read this manual carefully before starting or using the device. Always store the manual in the immediate vicinity of the device or its site of use.**



**Warning**

**Read all safety warnings and all instructions.** Failure to follow the warnings and instructions may result in electric shock, fire and/or serious injury. **Save all warnings and instructions for future reference.**

This appliance can be used by children aged from 8 years and above and persons with reduced physical, sensory or mental capabilities or lack of experience and knowledge if they have been given supervision or instruction concerning use of the appliance in a safe way and understand the hazards involved. Children shall not play with the appliance. Cleaning and user maintenance shall not be done by children without supervision.

## General safety

- Do not use the device in potentially explosive rooms or areas and do not install it there.
- Do not use the device in an aggressive atmosphere.
- Check accessories and connection parts for possible damage prior to every use of the device. Do not use any defective devices or device parts.
- Before carrying out maintenance, care or repair work on the device, remove the mains plug from the mains socket. Hold onto the mains plug while doing so.
- When positioning the device, observe the minimum distances from walls and other objects as well as the storage and operating conditions specified in the Technical annex.
- Do not remove any safety signs, stickers or labels from the device. Keep all safety signs, stickers and labels in legible condition.

## General safety warnings – Electrical safety

- The device is to be supplied with a rated residual current of no more than 30 mA by means of an RCD (Residual Current protective Device).
- Ensure that all electric cables outside of the device are protected from damage (e.g. caused by animals). Never use the device if electric cables or the power connection are damaged!
- The mains connection must correspond to the specifications in the Technical annex.
- Insert the mains plug into a properly fused mains socket.
- Switch the device off and disconnect the power cable from the mains socket when the device is not in use.
- Do not under any circumstances use the device if you detect damages on the mains plug or power cable. If the power cable is damaged, it must be replaced by the manufacturer, its service agent or similarly qualified persons in order to avoid a hazard. Defective power cables pose a serious health risk!
- Should there be a risk of flooding, install the plug connections in a flood-proof area. **There is a risk of electric shock!**
- Make sure that the mains voltage corresponds to the specifications on the nameplate.
- Have all electrical installations carried out by an expert according to the national regulations and the device-specific requirements.
- Do not use the power cable to drag the device.

- Hold onto the mains plug while pulling the power cable out of the mains socket.
- Protect the power supply cable against heat, oil and sharp edges. Make sure that the power supply cable is not crushed, kinked or subjected to other mechanical stresses.
- Only use splash-proof extension cables intended for outdoor use whilst observing the device's power input. Before using cable drums, always unroll the cable completely. Check the cable for damage. The use of extension cables which are not approved for outdoor use can result in injuries due to electric shock.
- Before performing any work on the device, in case of leaks in the water system, before taking work breaks or when not in use, remove the mains plug from the mains socket.

## General safety warnings – Personal safety

- Never use the device with persons or animals in the water or pumping medium or if they could access it. **There is a risk of electric shock!**
- Never insert any objects or limbs into the device.
- This appliance is not a toy. Keep away from children and animals.

## Device-specific safety warnings for deep well pumps

- Only operate the device in an upright position.
- Keep in mind, that lubricants are used within the device. These might potentially cause damages or contaminations if emitted. Do not use the device for drinking water or in garden ponds with either a fish population or valuable plants.
- Do not carry the device by holding it at the connection cable or hose. Do not fasten it there either.
- Do not place any objects on the device – not even to weight it down. The device will sink to the ground due to its own weight.
- After the set-up of the device, its mains plug must be readily accessible during operation.
- Prevent dry running of the device! Before start-up the device must be completely submerged in the pumping medium.
- Do not under any circumstances connect a power cable directly to the device. The device must not be used without the control box.
- Wear sturdy shoes to protect yourself against electric shock.

- Before taking the device into operation, have the following checked by an expert:
  - earthing, neutral conductor and RCD must be functioning properly and correspond to the national regulations,
  - electrical plug connections must be protected from moisture.
- Provide appropriate frost protection.

**Intended use**

The device TDP 5500 E / TDP 7500 E / TDP 7501 E is exclusively designed for pumping clear water from greater depths serving as service water for the home and garden.

The device can be applied for the following purposes:

- water withdrawal from wells and shafts
- rain water withdrawal from cisterns

In either case, the water must comply with the conditions specified in the technical data.

The device is fully submersible (watertight encapsulation) and can be immersed up to 20 m into the pumping medium.

Any use other than the intended use is regarded as misuse.

**Reasonably foreseeable misuse**

- The device is not suitable for continuous operation (e.g. as recirculation pump for ponds).
- Using the device in swimming pools and the like is prohibited.
- The device is not suitable as permanent, automatic overflow protection (of e.g. wells or fountains or for the regulation of the groundwater level). Use a stationary waste water pumping system for building and property drainage for these purposes.
- The device is not suitable for increasing the pressure of existing water supply networks.
- The device is not suitable for pumping potable water.
- The device must not be used for aggressive, abrasive, caustic, corrosive, combustible or explosive pumping media, e.g.:
  - brine
  - sandy water
  - food
  - cleaning agents
  - fuels (e.g. petrol, diesel)
  - oils
  - greases
  - petroleum
  - nitro-cellulose thinner
  - waste water from lavatories and urinal installations
- The device must not be used at freezing temperatures.
- Any unauthorised modifications, alterations or structural changes to the device are forbidden.

**Personnel qualification**

People who use this device must:

- be aware of the dangers that occur when working with electric devices in damp areas.
- have read and understood the instructions, especially the Safety chapter.

Installation and maintenance tasks which require the control box to be opened must only be carried out by a qualified electrician.

**Electrically skilled person**

Electrically skilled personnel must be able to read and understand electric circuit diagrams, to put electrical systems into service and to maintain them, to wire control cabinets, to ensure the functionality of electrical components and to identify possible hazards from electrical and electronic systems.

**Safety signs and labels on the device**

**Notice**

Do not remove any safety signs, stickers or labels from the device. Keep all safety signs, stickers and labels in legible condition.

The following safety signs and labels are attached to the device:



This label indicates the following safety warnings:

- Prevent dry running of the pump! Before start-up the pump must be completely submerged in the pumping medium.
- Carefully read the instructions before starting or using the pump.
- Do not under any circumstances connect a power supply cable directly to the pump! The pump may only be used in combination with the supplied control box.
- Insert the mains plug of the control box into a properly fused mains socket.

**WARNUNG**

- Die Öleinfüllschraube darf bei laufendem Motor nicht abgeschraubt werden!
- Beachten Sie, dass die Garantie verfällt, wenn die Pumpe ohne den mitgelieferten Schaltkasten betrieben wird.
- Schalten Sie die Stromversorgung ab, wenn sich nach Anlaufen des Motors ein ungewöhnliches Betriebsverhalten zeigt (wie z. B. starke Vibrationen an der Pumpe oder Druckleitung, schwankende Fördermenge o. Ä.).

**WARNING**

- The oil filling screw must not be screwed off when the motor is operating!
- Please note that the warranty will be voided if the pump is operated without the supplied control box.
- Turn off the power supply if after start-up of the motor the pump shows an unusual operational behaviour (such as strong vibrations at the pump or pressure line, a fluctuating flow rate or similar).

**AVERTISSEMENT**

- La vis de remplissage d'huile ne doit pas être dévissée pendant que le moteur fonctionne.
- Notez que la garantie est annulée si la pompe est utilisée sans le boîtier de commande fourni avec l'appareil.
- Coupez l'alimentation électrique si vous constatez un comportement inhabituel après le démarrage du moteur (par exemple de fortes vibrations de la pompe ou de la conduite sous pression, des fluctuations de débit, etc.).

This label indicates the following safety warnings:

- The oil filling screw must not be screwed off when the motor is operating!
- Please note that the warranty will be voided if the pump is operated without the supplied control box.
- Turn off the power supply if after start-up of the motor the pump shows an unusual operational behaviour (such as strong vibrations at the pump or pressure line, a fluctuating flow rate or similar).

**TROTEC**

**STEUERKASTEN FÜR EINPHASIGE ELEKTROMOTOREN  
CONTROL BOX FOR S.PH.ELECTRIC MOTORS  
COFFRET DE COMMANDE POUR MOTOR MONOPH.**

	HP	0.25	0.33	0.5	0.75	1	1.25	1.5	1.75	2	3	V 220-240 Hz 50	IP44		
	KONDENSATOR/CAPACITOR/CONDENSATEUR	μF	12	16	20	22	25	27	30	35	40	45	50	55	62
WÄRMESCH.AMP./PROT.THERM./THERAMAL PROT.EC.AMP															
	A	3	4	5	6	7	8	9	10	11	12	14	16	18	20

**ACHTUNG!!**  
TRENNEN SIE DIE STROMVERSORGUNG, BEVOR SIE DIE ABDECKUNG ÖFFNEN.

**ATTENZION!!**  
AVANT D'ENLEVER LE COUVERCLE COUPER L'ALIMENTATION ELECTRIC.

**CAUTION!!**  
BEFORE REMOVE THE COVER TAKE OFF THE ELECTRIC POWER .

This label indicates the following safety warning:

- Disconnect the power supply before opening the cover.

## Residual risks



### Warning of electrical voltage

Work on the electrical components must only be carried out by an authorised specialist company!



### Warning of electrical voltage

Before any work on the device, remove the mains plug from the mains socket!  
Do not touch the mains plug with wet or damp hands. Hold onto the mains plug while pulling the power cable out of the mains socket.



### Warning

Dangers can occur at the device when it is used by untrained people in an unprofessional or improper way! Observe the personnel qualifications!



### Warning

The device is not a toy and does not belong in the hands of children.



### Warning

Risk of suffocation!  
Do not leave the packaging lying around. Children may use it as a dangerous toy.

### Notice

If you store or transport the device improperly, the device may be damaged.  
Note the information regarding transport and storage of the device.

## Behaviour in the event of an emergency

1. Switch the device off.
2. Disconnect the device from the mains: Hold onto the mains plug while pulling the power cable out of the mains socket.
3. Do not reconnect a defective device to the mains.

## Overheating protection

The device is provided with a thermal protection circuit which is activated by overheating of the device and then switches the device off.

Switch the device off and let it cool down. Investigate the cause of overheating. Should the problem persist, please contact the customer service.

**Information about the device**

**Device description**

The device TDP 5500 E / TDP 7500 E / TDP 7501 E is particularly well suited for pumping clear water from greater depths, e.g. from wells or shafts.

The device is able to pump up to 6000 l (TDP 5500 E / TDP 7501 E) or 4800 l (TDP 7500 E) per hour from a working depth of up to 20 metres. In doing so, the device reaches a delivery head of up to 58 metres (TDP 5500 E) or 93 metres (TDP 7500 E) or 90 metres (TDP 7501 E).

The device is equipped with an external control box allowing for safe operation of the device outside the place of installation at all times. An overload switch protects the device against damage caused by overload.

The water temperature must not exceed 35 °C.



**Info**

The illustrations in these instructions feature the device TDP 5500 E by way of example. The represented operating steps and explanations also apply to device TDP 7500 E / TDP 7501 E unless otherwise mentioned.

**Device depiction**

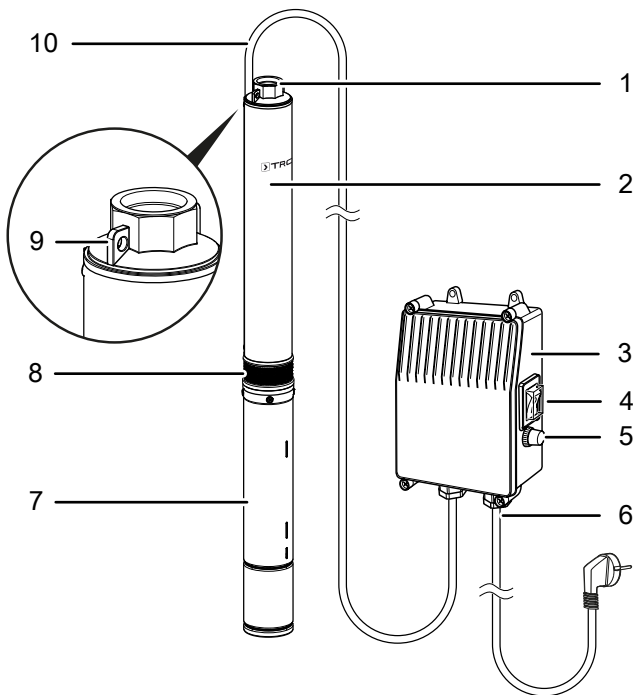

No.	Designation
1	Connection for pressure line with 1 ¼" internal thread
2	Pump
3	Control box
4	On/off switch with protective cover
5	Overload switch with protective cover
6	Power cable
7	Motor
8	Dirt strainer
9	Suspension eye
10	Control box connection cable

**Transport and storage**

**Notice**

If you store or transport the device improperly, the device may be damaged.  
Note the information regarding transport and storage of the device.

**Transport**

**Before** transporting the device, observe the following:

- Hold onto the mains plug while pulling the power cable out of the mains socket.
- Do not use the connection cable to drag the device.
- Do not carry the device by holding it at the connection cable or hose.

**Storage**

When the device is not being used, observe the following storage conditions:

- Store the device in a dry location and protected from frost and heat.
- Store the device in an upright position where it is protected from dust and direct sunlight.
- If required, use a cover to protect the device from invasive dust.
- Check whether there is residual water left in the device, and drain any residual water to prevent rust formation.
- Put the protective cap on the pressure connection to protect the inside of the device against dust and dirt.

If you do not use the device for an extended period of time, it must be cleaned thoroughly after its last application and before recommissioning. Deposits and residues could lead to start-up difficulties.

For restart, please proceed according to the Start-up chapter.



## Assembly and installation

### Scope of delivery

- 1 x Deep well pump
- 1 x Control box
- 1 x Manual

### Unpacking the device

1. Open the cardboard box and take the device out.
2. Completely remove the packaging.
3. The device is additionally packed in a cardboard tube (11). One end of this tube is closed by a screwed-down cover (12). Loosen the screws with a suitable screwdriver and remove the cover (12).

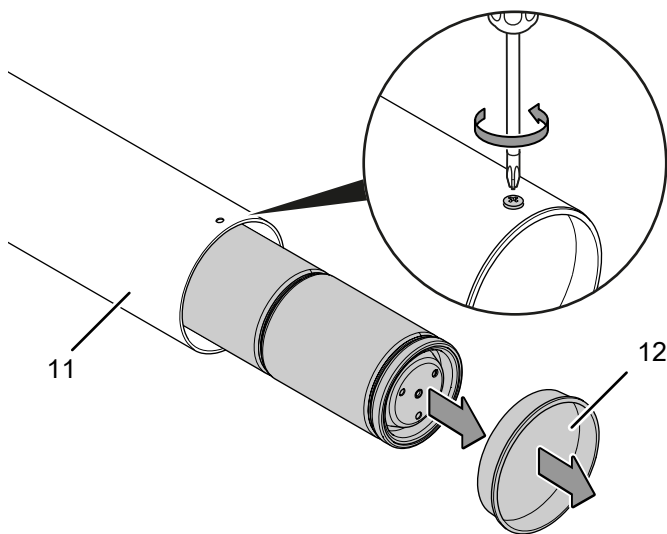

4. Carefully pull the device out of the cardboard tube (11).
5. Fully unwind the power cable. Make sure that the power cable is not damaged and that you do not damage it during unwinding.

### Start-up

#### Connecting the pipe or hose line

The device may be operated using either a hose line or a pipe. Ex factory, the device is delivered with a 1 ¼" internal thread.

Please observe the following information regarding water discharge:

- The device cannot be moved flexibly when using a solid pipe.
- Please note that the conveying capacity declines with an increasing height of the pressure line.

#### Notice

If you want to connect a flexible hose as pressure line, do not use a suction hose or a non-pressure-resistant hose. Use pressure-resistant hoses only.

#### Connecting the pressure line



#### Warning

Make sure that all parts of the pressure line are installed professionally. In case of an improper assembly or when using unsuitable parts, there is a risk of injury due to the pressurized pumping medium.

1. Remove the protective cap (13) from the pressure connection (1).

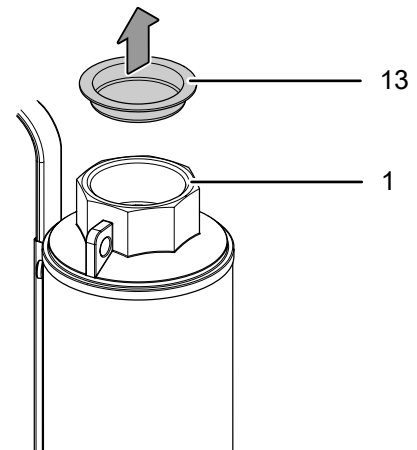

#### Notice

Keep the protective cap (13) of the pressure connection so you can use it when storing the pump to protect the inside of the pump against dust and dirt.

2. Connect the pressure line to the pressure connection (1) using a suitable adapter (1 ¼"). To do so, apply thread seal tape (e.g. Teflon tape) to the threaded connector of the pressure line to ensure a leak-proof connection.

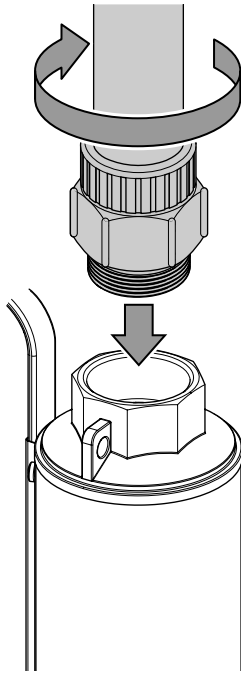

### Installing the control box



#### Warning of electrical voltage

Work on the electrical components must only be carried out by a qualified electrician!



#### Warning of electrical voltage

Disconnect the power supply before opening the cover!



#### Warning of electrical voltage

The device must not be operated without the control box (3).

1. Make sure that there is a socket secured with a 30 mA residual current device available near the place of installation.
2. Install the control box (3) at a suitable position according to the protection class (protected from weather exposure and spray water, in a flood-proof area). Please note that the control box must not be installed inside the well shaft.
3. Have the connection cable (10) connected to the control box (3) by a qualified electrician in accordance with the wiring diagram in the chapter Technical annex.

### Setting up the device

Please observe the following information regarding the device set-up and before switching the device on:

- The shaft/the drill hole should be vertical and the shaft walls should not have any protruding edges or projections.
- The shaft/the drill hole should have an edge length/a diameter of at least 110 mm.
- Check whether the hose or pipe was attached properly.
- Make sure that the connection cable (10) is not under tensile load and has enough clearance.
- Make sure that the mains connection corresponds to the specifications provided in the technical data.
- Check the mains socket for its proper condition. The mains socket's fusing must be sufficient.
- Make it impossible for moisture to reach mains plug or socket. **There is a risk of electric shock!**



#### Warning of electrical voltage

There is a risk of electric shock when submerging the device in the pumping medium. Before submerging the device in the pumping medium, please note the following:

- Make sure that the mains plug is removed.
- Check the mains plug, the power cable (6) and the connection cable (10) for damage. Do not under any circumstances use the device if you detect damages on the mains plug, power cable (6) or connection cable (10).



#### Warning of electrical voltage

Electric shock due to damaged connection cable (10). Do not under any circumstances use the connection cable (10) for lowering, securing, positioning or lifting the device. Only use a suitable cord or rope, e.g. a nylon cord or a wire rope.



#### Warning

There is a risk of falling into the shaft or drill hole. Position the device in a way that the shaft or drill hole opening is closed before, during and after operation to prevent persons or animals from falling in.

#### Notice

At the bottom of ponds and other waterbodies deposits may have accumulated over time. To prevent the device from being damaged, it should not be lowered all the way to the ground. Observe a minimum distance of 50 cm to the ground.



1. Fasten a suitable cord or rope, e.g. a nylon cord or a wire rope, to the suspension eye (9) on top of the device.

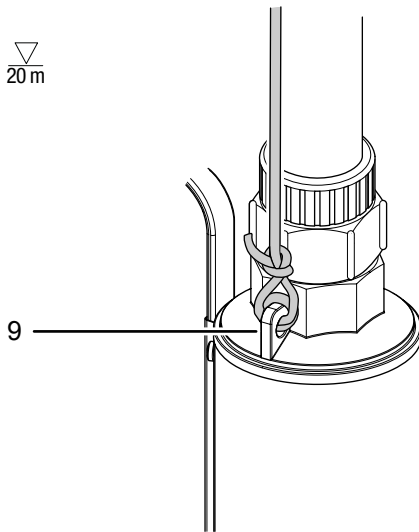

## Operation

### Switching the device on

Once you have completely installed the device as described in the chapter Assembly and start-up, you can switch it on.



#### Warning of electrical voltage

Do not touch the mains plug with wet or damp hands.

#### Notice

Please note that the device is designed for max. 20 switch-on/switch-off operations per hour. Before every restart, wait for at least 3 minutes.

1. Plug the mains plug into a sufficiently fused mains socket.
2. Switch the device on by setting the on/off switch (4) to position I.

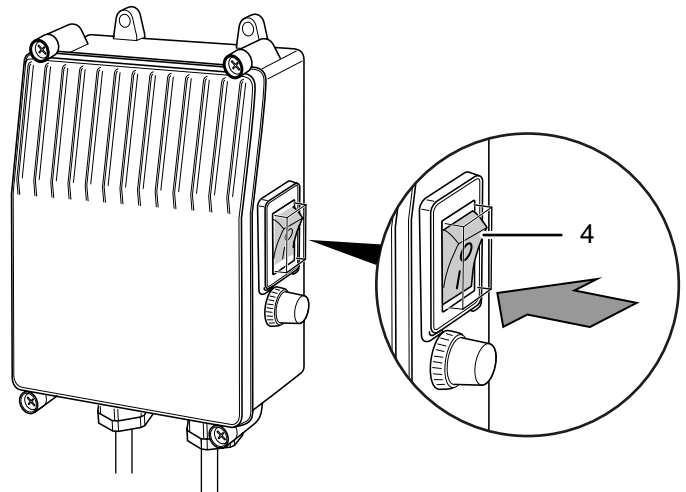

2. Slowly lower the device and the cord/rope into the pumping medium. Pay attention to the following:
  - ⇒ The device must be lowered into the pumping medium perpendicularly.
  - ⇒ The device must be completely submerged in the pumping medium. Regularly check the water level to prevent the device from running dry.
  - ⇒ Observe a minimum distance of 50 cm to the ground (see also schematic representation in the chapter Technical annex).
3. Attach the cord or rope to an easily accessible position, so you can pull the device back out as required.

### Installation with pressure switch TDP DS / TDP DSP (optional)



#### Warning of electrical voltage

Work on the electrical components must only be carried out by an authorised specialist company!

For switching a connected deep well pump on or off and for monitoring the pressure in the pipe, the device can be installed together with pressure switch TDP DS or TDP DSP.

See also chapter Available accessories.

#### Recommendation for usage:

- in order to install and use the device in a permanent / stationary manner, use the pressure switch TDP DS
- in order to install and use the device in a temporary / location-independent manner, use the pressure switch TDP DSP

3. After switch-on, regularly check whether the device operates correctly. Turn off the power supply if after start-up of the motor the pump shows an unusual operational behaviour (such as strong vibrations at the pump or pressure line, a fluctuating flow rate or similar). If you leave the device unattended for a longer period of time, interrupt the device's power supply.

**Switching the device off**

1. Switch the device off by setting the on/off switch (4) to position 0.

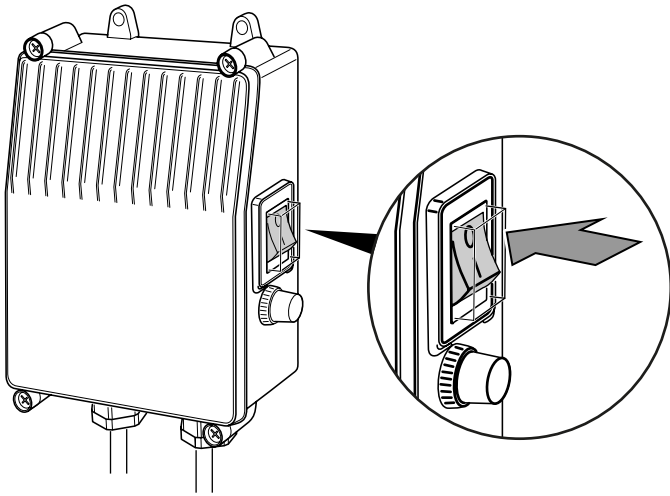

**Shutdown**



**Warning of electrical voltage**

Do not touch the mains plug with wet or damp hands.

1. Switch the device off by setting the on/off switch (4) to position 0.
2. Hold onto the mains plug while pulling the power cable out of the mains socket.
3. Pull the device out of the pumping medium by means of the cord or rope.
4. Disconnect the pressure line.
5. Clean the device according to the Maintenance chapter.
6. Store the device according to the Storage chapter.

**Available accessories**



**Warning**

Only use accessories and additional equipment specified in the instructions. Using insertion tools or accessories other than those specified in the instructions may cause a risk of injury.

Accessories	Article number
TDP DSP (with plug)	4.610.000.291
TDP DS (without plug)	4.610.000.290

**Errors and faults**



**Warning of electrical voltage**

Do not touch the mains plug with wet or damp hands.



**Warning of electrical voltage**

**Tasks which require the device to be opened must only be carried out by authorised specialist companies or by the manufacturer.**

**Notice**

Wait for at least 3 minutes after maintenance and repair work. Only then switch the device back on.

- Switch the device off.
- Hold onto the mains plug while pulling the power cable out of the mains socket.

The device has been checked for proper functioning several times during production. If malfunctions occur nonetheless, check the device according to the following list.

**The device does not start:**

- Check the power connection.
- Check the power cable and mains plug for damage.
- Check the on-site fusing.
- The device might have overheated and the thermal protection circuit is activated.

If so, wait for approx. 10 minutes before restarting the device. If the device is not starting, have the electricians checked by a specialist company or by Trotec.

- The water temperature is above 35 °C and the thermal protection circuit is activated.

**The device is running, but not pumping any water:**

- Check whether the dirt strainer (8) is clogged. Remove any obstructions.
- Check whether the water level is too low or the device is not completely submerged. If necessary, submerge the device deeper into the water.
- Check whether the used hose diameter is too small.
- Check whether the hose line is kinked or blocked. Remove kinks and / or blockages.

**The device switches off after a brief runtime:**

- Check the water for dirt. If the water is too dirty, the device will become hot and the thermal protection circuit will switch the device off.
- Check whether the water temperature is too high. The device might have overheated due to a too high water temperature and the thermal protection circuit is activated.
- Check the power connection.
- Check the power cable and mains plug for damage.
- Check the on-site fusing.

**Insufficient or decreasing conveying capacity:**

- Check whether the dirt strainer (8) is clogged. Remove any obstructions.
- Check the hose diameter and the delivery head. An excessive delivery head paired with a small hose diameter can cause a reduction of the conveying capacity.
- Check whether the hose line is kinked or blocked. Remove kinks and / or blockages.

**The device still does not operate correctly after these checks:**

Please contact the customer service. If necessary, bring the device to an authorised specialist electrical company or to the manufacturer for repair.

**Maintenance****Activities required before starting maintenance****Warning of electrical voltage**

Do not touch the mains plug with wet or damp hands.

- Switch the device off.
- Hold onto the mains plug while pulling the power cable out of the mains socket.

**Notes on maintenance**

Inside the device, there are no parts that need to be maintained or lubricated by the user.

**Safety signs and labels on the device**

Check the safety signs and labels attached to the device at regular intervals. Replace illegible safety signs!

**Cleaning**

- Clean the device with a soft, damp and lint-free cloth. Protect electrical components from moisture. Do not use any aggressive cleaning agents such as cleaning sprays, solvents, alcohol-based or abrasive cleaners to dampen the cloth.
- Rinse the inside of the device with clear, lukewarm water.

**Technical annex**
**Technical data**

Parameter	Value		
Model	TDP 5500 E	TDP 7500 E	TDP 7501 E
Max. flow rate	100 l/min	80 l/min	100 l/min
Max. delivery head	58 m	93 m	90 m
Max. submersion depth	▽ 20 m	▽ 20 m	▽ 20 m
Speed	2850 rpm	2850 rpm	2850 rpm
Max. pressure	5.8 bar	9.3 bar	9 bar
Min. ambient temperature	0 °C	0 °C	0 °C
Max. ambient temperature	35 °C	35 °C	35 °C
Power supply	220 V - 240 V ~ 50 Hz	220 V - 240 V ~ 50 Hz	220 V - 240 V ~ 50 Hz
Number of phases	1	1	1
Max. power consumption	1100 W	1500 W	1800 W
Max. pump capacity	550 W	750 W	1100 W
Protection type of the pump	IP68	IP68	IP68
Protection type of the control box	IP44	IP44	IP44
Protection class	I	I	I
Connection type	CEE 7/7	CEE 7/7	CEE 7/7
Cable length of the control box	1.2 m	1.2 m	1.2 m
Cable length of the pump	23 m	23 m	23 m
Min. drill hole diameter	110 mm	110 mm	110 mm
Minimum distance to the ground	0.5 m	0.5 m	0.5 m
Threaded connector, inner diameter	1¼"	1¼"	1¼"
Pump dimensions (length x width x height)	780 x 92 x 100 (mm)	930 x 92 x 100 (mm)	1180 x 85 x 86 (mm)
Pump weight	13.5 kg	15.5 kg	20 kg
Control box dimensions (length x width x height)	143 x 185 x 70 (mm)	143 x 185 x 70 (mm)	143 x 185 x 70 (mm)
Control box weight	0.74 kg	0.74 kg	0.74 kg
<b>Conditions for the pumping medium (water)</b>			
Max. water temperature	35 °C		
Max. particle size	2.3 mm		
Max. chloride content	1.5 mg/l		
Max. hydrogen sulphide content	400 mg/l		
Min. pH	6.5		
Max. pH	8.0		

**Schematic representation**

TDP 5500 E

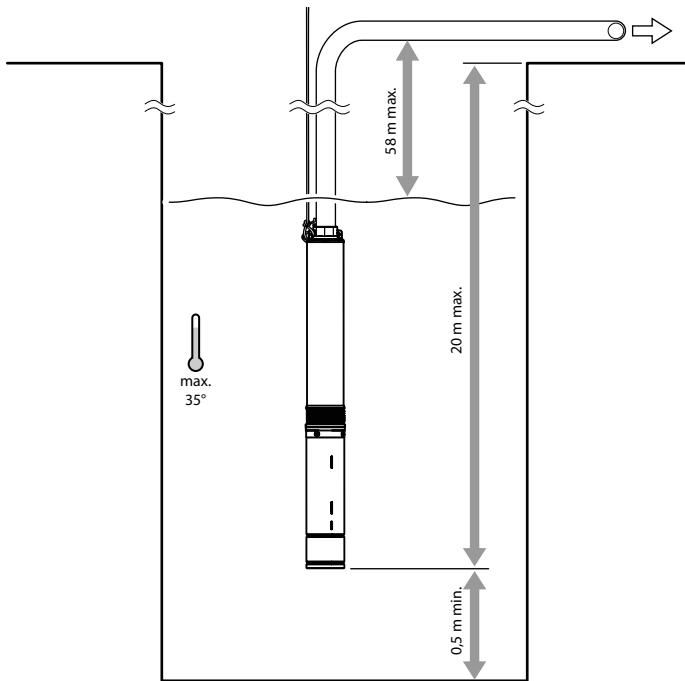

TDP 7501 E

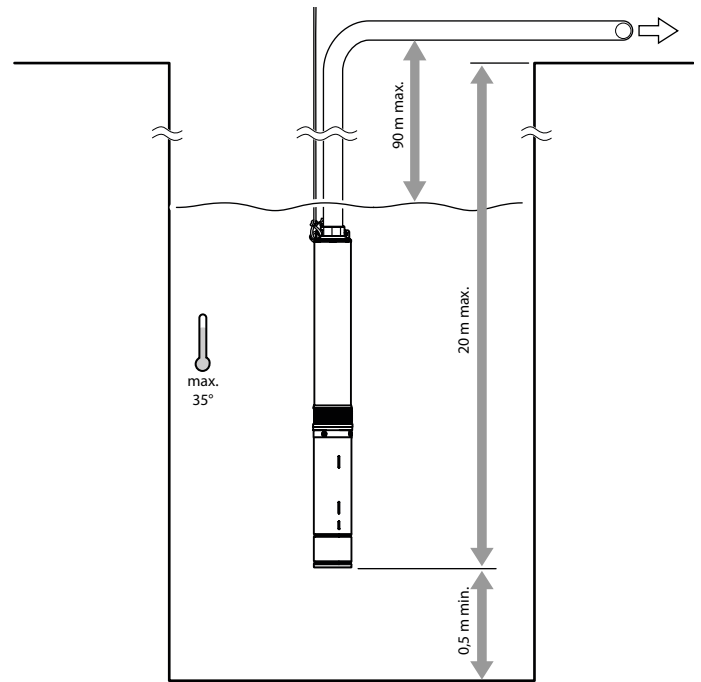

TDP 7500 E

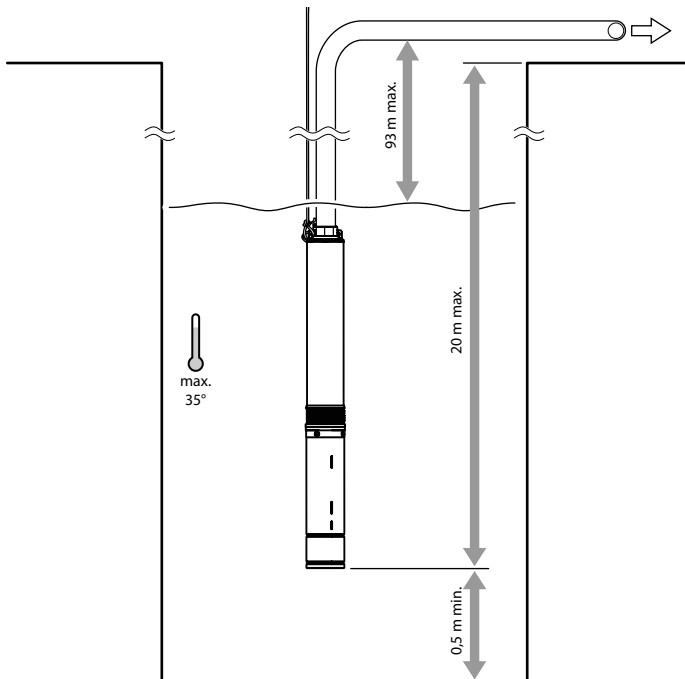

**Performance chart (delivery head / flow rate)**

**TDP 5500 E**

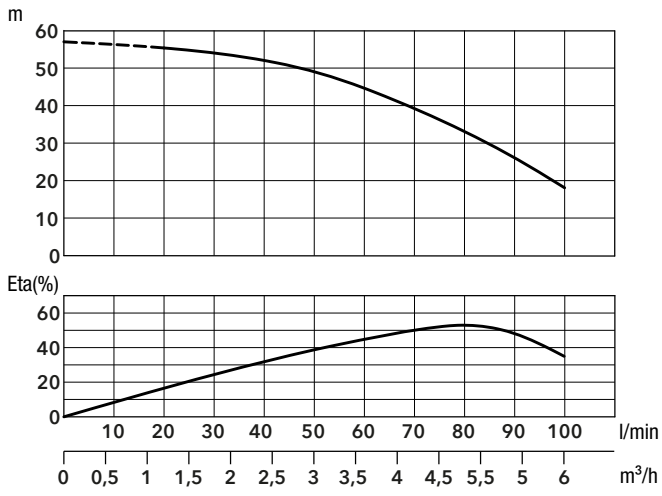

**TDP 7501 E**

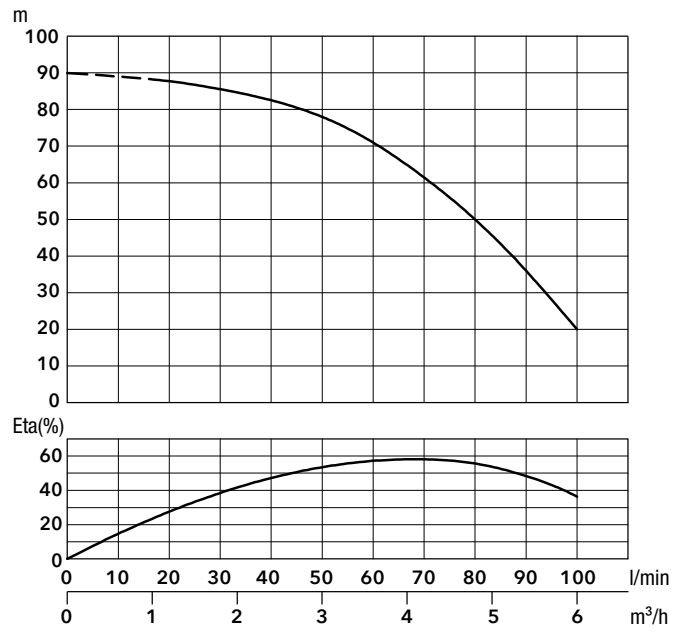

**TDP 7500 E**

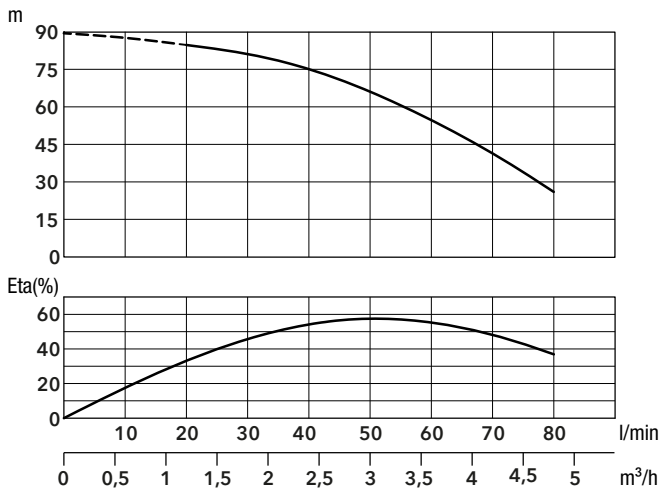



Wiring diagram

TDP 5500 E / TDP 7500 E

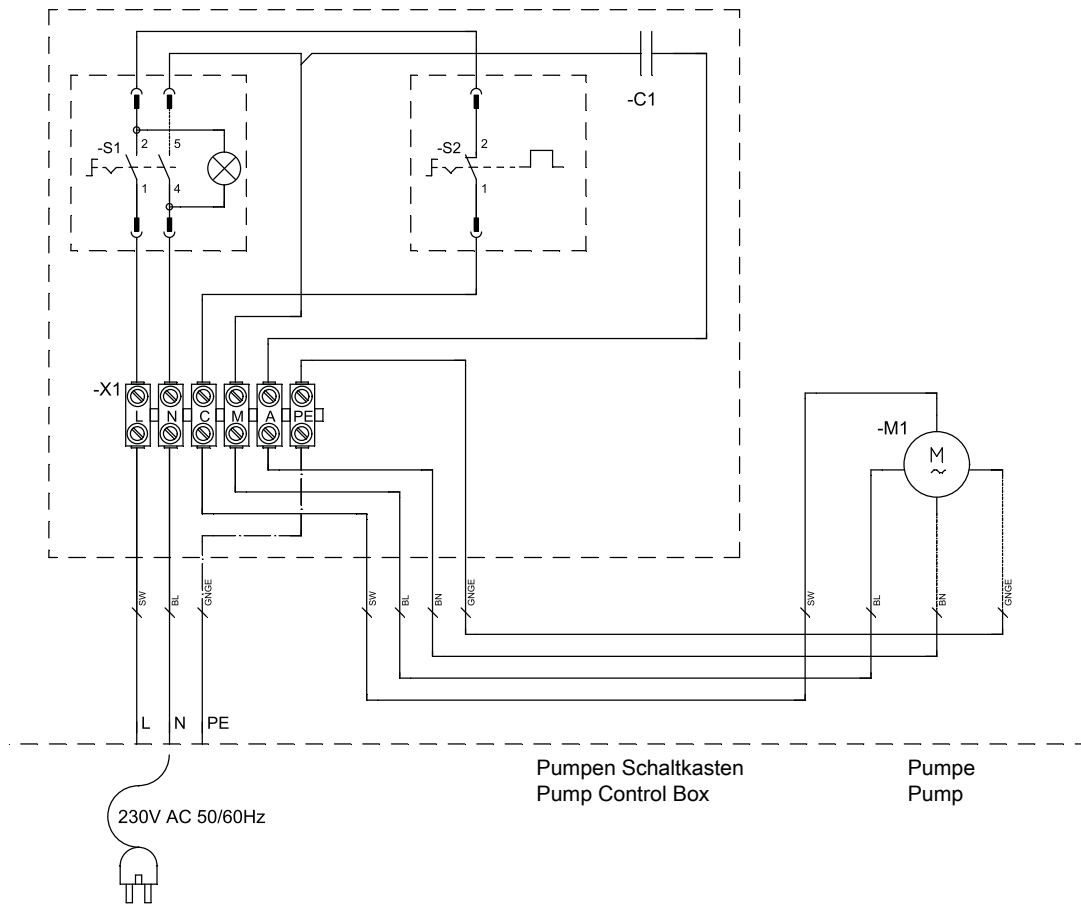

Aderfarben / wire colors

sw = schwarz / black

bn = braun / brown

rt = rot / red

ge = gelb / yellow

bl = blau / blue

gnge = grün gelb / green yellow

TDP 7501 E

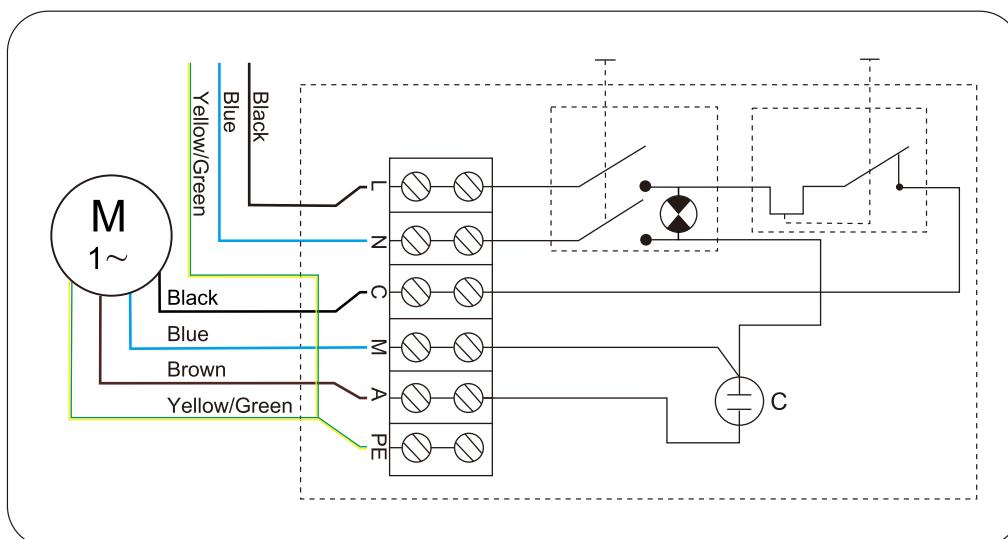

**Overview and list of spare parts**

**Note:** The position numbers of the spare parts differ from those describing the positions of the components mentioned in these instructions.

**Control box**

**TDP 5500 E / TDP 7500 E / TDP 7501 E**

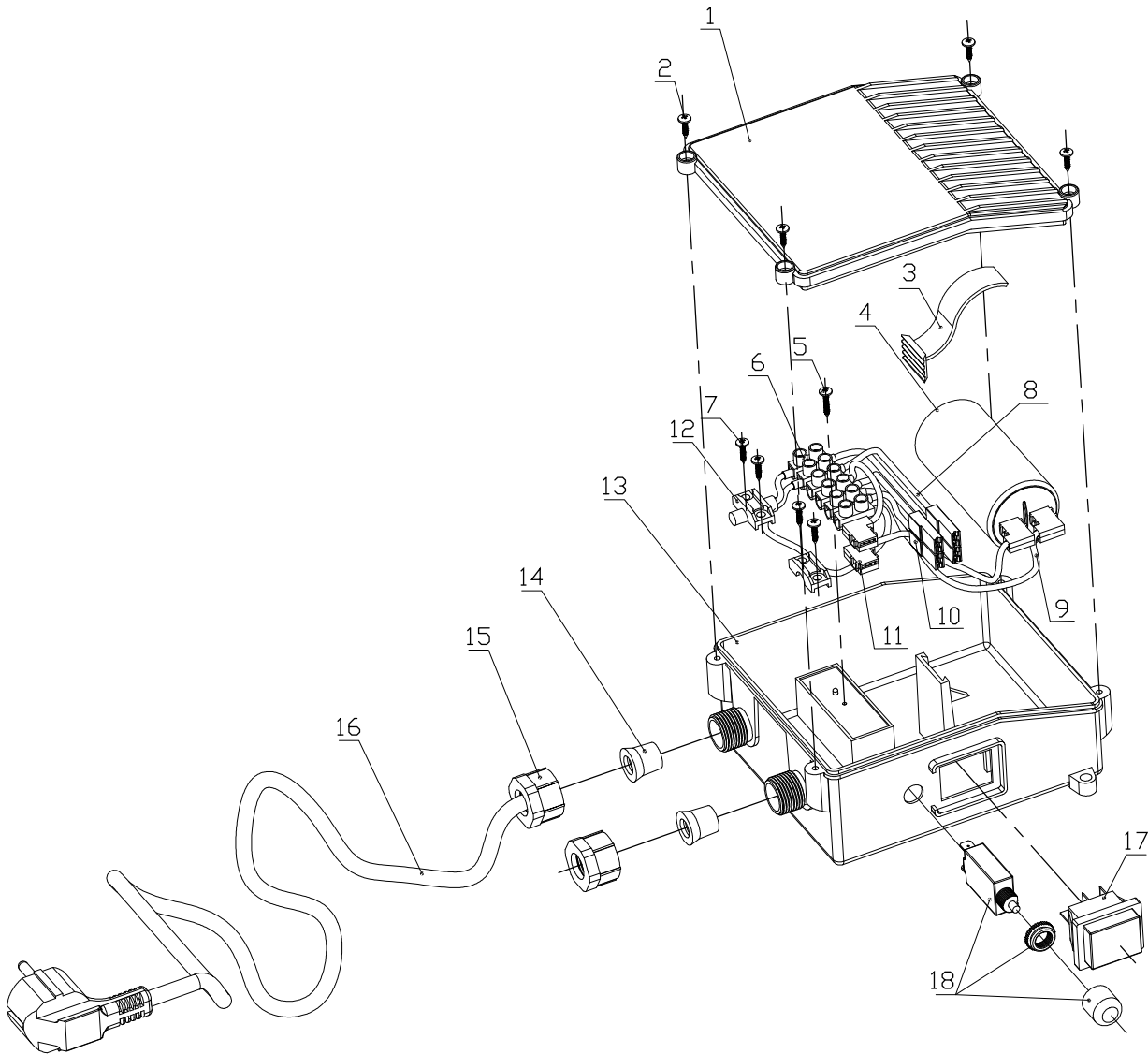

No.	Spare part	Quantity	No.	Spare part	Quantity
1	Control box cover	1	10	Lead wire dual with terminal	1
2	Screw	4	11	Lead wire with L terminal	1
3	Capacitor Holder	1	12	Impacted Block	2
4	Capacitor	1	13	Control box shell	1
5	Pan Head Screw	1	14	Line out Bushing	2
6	Junction	1	15	Impacted Ring	2
7	Truss Head Screw	4	16	Power cord	1
8	Lead wire with terminal	2	17	Power Switch	1
9	Lead wire with L terminal	2	18	Overload protector	1

# Pump

## TDP 5500 E / TDP 7500 E

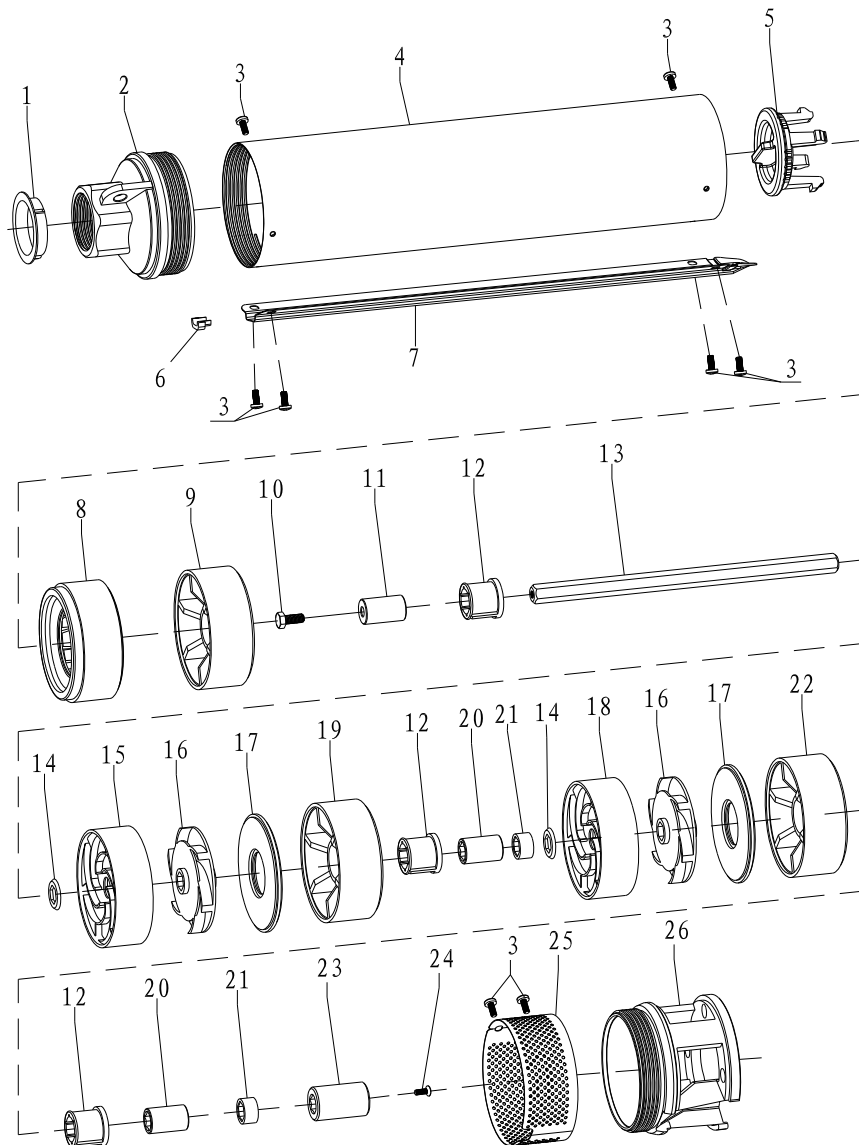

No.	Spare part	Quantity	No.	Spare part	Quantity
1	Outlet cover	1	14	Impeller gasket	8
2	Outlet	1	15	Diffuser	1
3	Screw M4X6	8	16	Impeller	8
4	Pump casing	1	17	Impeller cover	1
5	Check valve	1	18	Impeller sets	7
6	Cable sheath	1	19	Middle support	1
7	Cable guard	1	20	Lower sleeve	1
8	Guides	1	21	Plastic bushing	1
9	Upper support	1	22	Bottom support	1
10	Bolt M5X10	1	23	Coupling	1
11	Upper bearing	1	24	Screw M5X12	1
12	Rubber bearing	2	25	Mesh cover	1
13	Pump shaft	1	26	Inlet	1

**Pump motor**

**TDP 5500 E / TDP 7500 E**

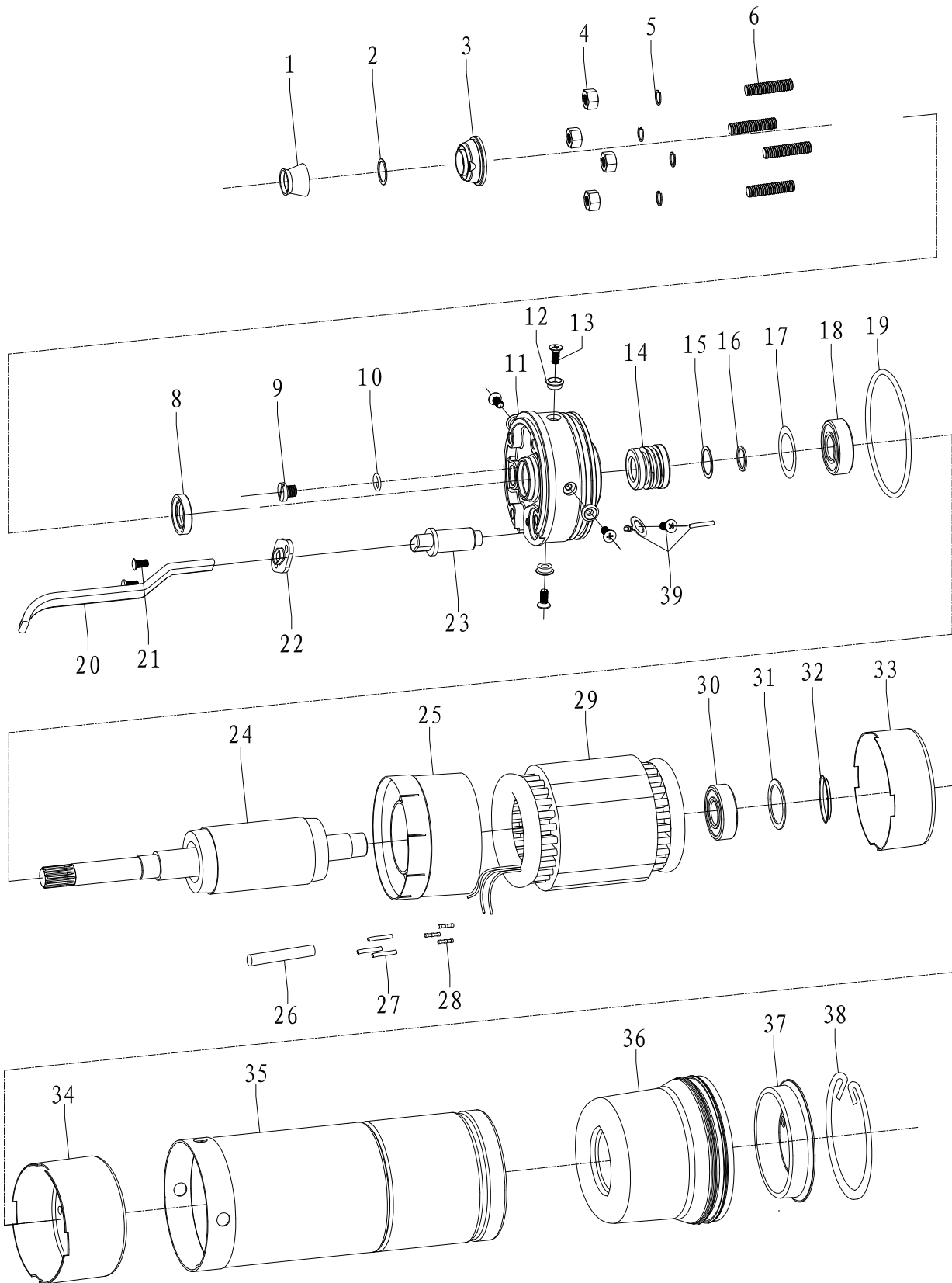

No.	Spare part	Quantity	No.	Spare part	Quantity
1	Rubber sleeve	1	21	Screw	2
2	Anti-sand washer	1	22	Cable guard	1
3	Anti-water cover	1	23	Plug	1
4	Hex nut	4	24	Stator	1
5	Spring washer	4	25	Upper bushing	1
6	Bolt6”X30	4	26	Fiberglass Sleeving	1
8	Framework oil seal	1	27	Hot-melt hose	3
9	Oil bolt	1	28	Terminal	3
10	O-Ring	1	29	Coil	1
11	Brass top chock	1	30	6203T bearing	1
12	Location washer	4	31	Bearing Gasket	1
13	Screw	4	32	Bottom chock gasket	1
14	Mechanical seal	1	33	Lower bushing	1
15	Flat gasket	1	34	Bottom chock	1
16	Flat gasket	1	35	Motor casing	1
17	Wave washer	1	36	Oil bag	1
18	6203 bearing	1	37	Base	1
19	O ring	1	38	Circlip	1
20	Motor cables	1	39	Grounding gasket	1

**Pump  
TDP 7501 E**

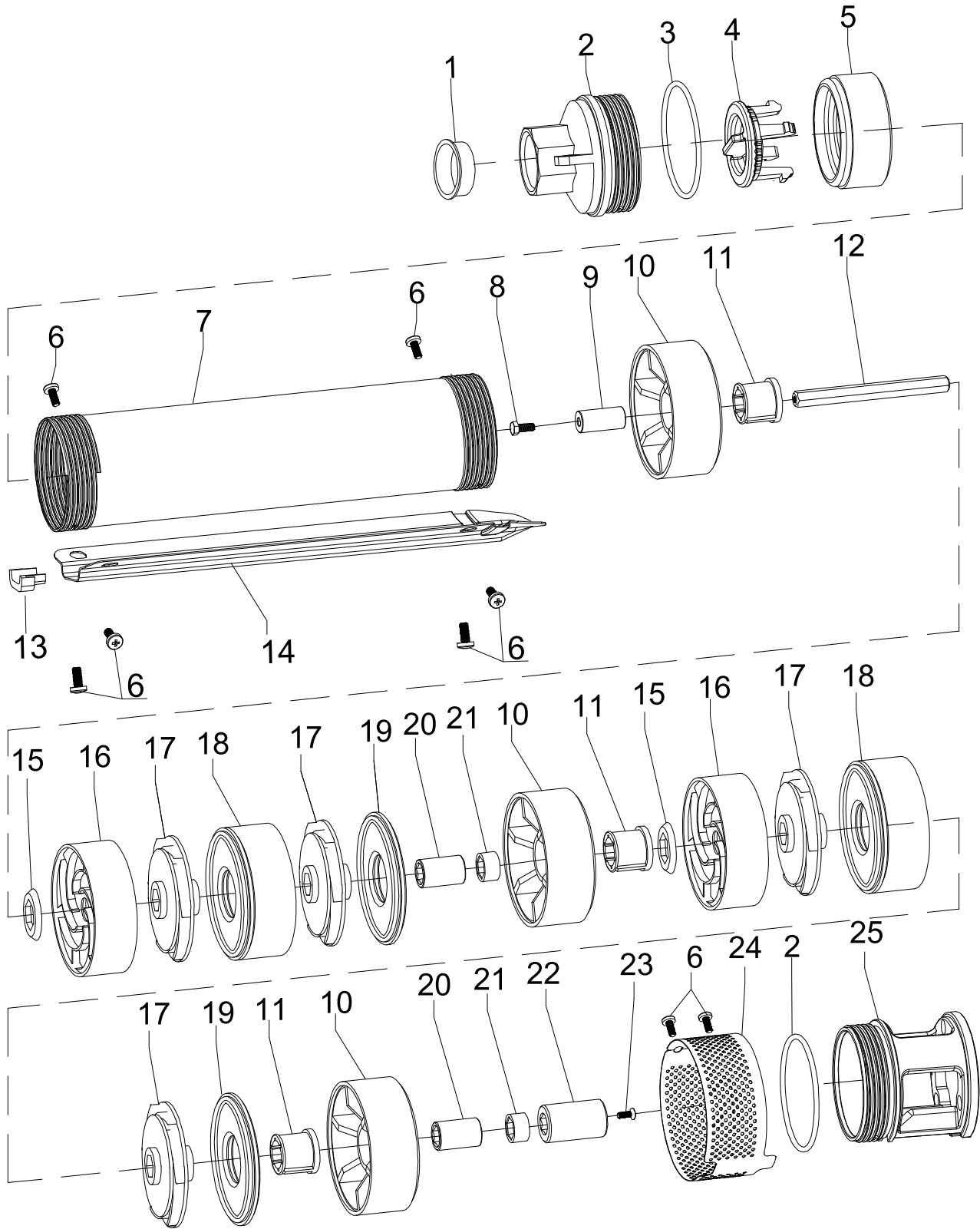



No.	Spare part	Quantity	No.	Spare part	Quantity
1	Outlet cover	1	14	Cable guard	1
2	Outlet	1	15	Impeller gasket	16
3	O-ring	2	16	Diffuser	16
4	Check valve	1	17	Impeller	16
5	Guides	1	18	Impeller sets	16
6	Screw	8	19	Impeller cover	16
7	Pump casing	1	20	Lower shaft sleeve	2
8	Bolt	1	21	Plastic shaft sleeve	2
9	Upper shaft sleeve	1	22	Coupling	1
10	Upper support	1	23	Screw	1
11	Rubber bearing	1	24	Mesh cover	1
12	Pump shaft	1	25	Inlet	1
13	Cable sheath	1			

**Pump motor  
TDP 7501 E**

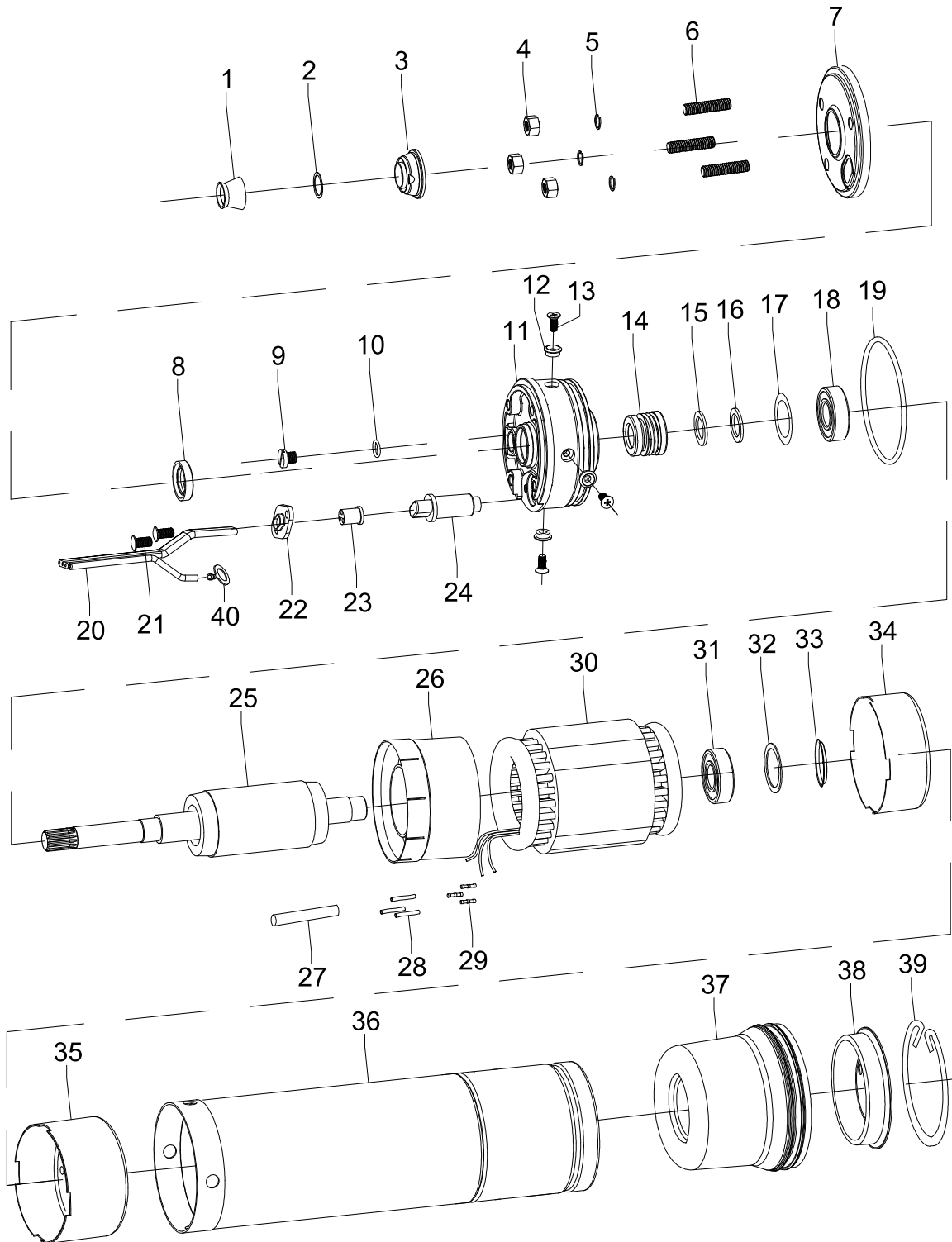

No.	Spare part	Quantity	No.	Spare part	Quantity
1	Rubber sleeve	1	19	Motor cables	1
2	Gasket	1	20	Screw	2
3	Anti-water cover	1	22	Cable guard	1
4	Hex nut	4	25	Stator	1
5	Spring washer	4	26	Upper bushing	1
6	Bolt "X30	4	27	Fiberglass Sleeving	1
7	Upper bearing cover	1	28	Hot-melt hose	3
8	Skeleton oil seal	1	29	Terminal	3
9	Oil bolt	1	30	Coil	1
10	O-ring	1	31	6203T bearing	1
11	Brass top chock	1	32	Bearing Gasket	1
12	Location washer	4	33	Bottom chock gasket	1
13	Screw	4	34	Lower bushing	1
14	Mechanical seal	1	35	Bottom chock	1
15	Flat gasket	1	36	Motor casing	1
16	Wave washer	1	37	Oil bag	1
17	Upper bearing	1	38	Base	14
18	O ring	1	39	Circlip	1

## Disposal

Always dispose of packing materials in an environmentally friendly manner and in accordance with the applicable local disposal regulations.



The icon with the crossed-out waste bin on waste electrical or electronic equipment is taken from Directive 2012/19/EU. It states that this device must not be disposed of with the household waste at the end of its life. You will find collection points for free return of waste electrical and electronic equipment in your vicinity. The addresses can be obtained from your municipality or local administration. You can also find out about other return options that apply for many EU countries on the website <https://hub.trotec.com/?id=45090>. Otherwise, please contact an official recycling centre for electronic and electrical equipment authorised for your country.

The separate collection of waste electrical and electronic equipment aims to enable the re-use, recycling and other forms of recovery of waste equipment as well as to prevent negative effects for the environment and human health caused by the disposal of hazardous substances potentially contained in the equipment.

### Only for United Kingdom

According to Waste Electrical and Electronic Equipment Regulations 2013 (SI 2013/3113) (as amended) devices that are no longer usable must be collected separately and disposed of in an environmentally friendly manner.

## Declaration of conformity

Declaration of conformity in accordance with the EC Machinery Directive 2006/42/EC, Annex II, Part 1, Section A

We – Trotec GmbH – declare in sole responsibility that the product designated below was developed, constructed and produced in compliance with the requirements of the EC Machinery Directive in the version 2006/42/EC.

**Product model / product:** TDP 5500 E  
TDP 7500 E  
TDP 7501 E

**Product type:** deep well pump

**Year of manufacture as of:** 2024

### Relevant EU directives:

- 2011/65/EU
- 2012/19/EU
- 2014/30/EU
- 2015/863/EU

### Applied harmonised standards:

- EN 60335-1:2012  
EN 60335-1:2012/AC:2014  
EN 60335-1:2012/A11:2014  
EN 60335-1:2012/A13:2017  
EN 60335-1:2012/A15:2021

### Applied national standards and technical specifications:

- EN IEC 55014-1:2021
- EN IEC 55014-2:2021
- EN IEC 60335-2-41:2021/A11:2021
- EN IEC 61000-3-2:2019/A1:2021
- EN 61000-3-3:2013/A2:2021
- EN 62233:2008

### Manufacturer and name of the authorised representative of the technical documentation:

Trotec GmbH  
Grebener Straße 7, D-52525 Heinsberg  
Phone: +49 2452 962-400  
E-mail: [info@trotec.de](mailto:info@trotec.de)

Place and date of issue:  
Heinsberg, 06.06.2024

Joachim Ludwig, Managing Director

Trotec GmbH

Grebener Str. 7  
D-52525 Heinsberg

☎ +49 2452 962-400

☎ +49 2452 962-200

✉ [info@trotec.com](mailto:info@trotec.com)

[www.trotec.com](http://www.trotec.com)